

PMI.PMP.v2022-11-03.q487

Exam Code:	PMP
Exam Name:	Project Management Professional (2025 Version)
Certification Provider:	PMI
Free Question Number:	487
Version:	v2022-11-03
# of views:	5951
# of Questions views:	4870
https://www.dumpsdb.com/dumps/PMI/PMP/PMI.PMP.v2022-11-03.q487	

NEW QUESTION: 1

One of your friends is project manager in Telecommunication Company. She is currently managing a project developing a voice over IP. The gateway offers a comprehensive approach to implementing high density, carrier class voice over packet gateway applications. She is in the process of developing the project schedule, and has determined that the project has 44 critical paths. Which of the following best describe how the project will be impacted?

- A. There is no significant impact from having multiple critical paths
- B. Project will cost more
- C. Project risk will increase
- D. Project will require more resources

Answer: C ([LEAVE A REPLY](#))

NEW QUESTION: 2

Participative Management:

- A. assumes that members avoid work and responsibility.
- B. Both 1) involves the solicitation of information from all team members, and 2) A and suggests the sharing of power and decision making
- C. employs a Theory X style of leadership.
- D. suggests the sharing of power and decision making.
- E. involves the solicitation of information from all team members.

Answer: B ([LEAVE A REPLY](#))

NEW QUESTION: 3

You are the Project Manager on a project where \$4M US will be spent on procuring telecom equipment. As negotiations begin between your company and the vendor, you are approached by the vendor's sales representative who offers you a trip to Las Vegas if you can "help" the process along by ensuring that the contract has accelerated payment terms compared to typical contracts. What is your professional and social responsibility?

- A. Decline the trip until after the contract has been signed
- B. The work you have put in on the project has been demanding and you deserve the trip
- C. Decline the trip and have it offered to your manager
- D. Decline the trip because it is not in the best interest of the company

Answer: D ([LEAVE A REPLY](#))

NEW QUESTION: 4

Communication is the PRIME responsibility of a Project:

- A. Manager in a projectized environment
- B. Coordinator
- C. Expeditor
- D. Manager in a weak matrix

Answer: C ([LEAVE A REPLY](#))

NEW QUESTION: 5

A major project is unable to access the US\$12 million funding allocated for the project. This prevents the start of the procurement process and is already leading to costly delays.

What should the project manager do?

- A. Invite the finance department to the next project demo.
- B. Use the currently available resources.
- C. Review the project requirements.
- D. Escalate to the project steering committee.

Answer: D ([LEAVE A REPLY](#))

NEW QUESTION: 6

The cumulative CPI has been shown to be relatively stable after what percentage of project completion?

- A. 5% to 10%
- B. 15% to 20%
- C. 25% to 35%
- D. 50% to 75%

Answer: B ([LEAVE A REPLY](#))

Explanation/Reference:

Explanation:

The CPI has been proven to be an accurate and reliable forecasting tool. Researchers have found that the cumulative CPI does not change by more than 10% once a project is approximately 20% complete. The CPI provides a quick statistical forecast of final project costs.

NEW QUESTION: 7

What is the most accurate rough order of magnitude (ROM)?

- A. In the Initiation phase, the estimate is in the range of +/- 50%.
- B. In the Monitoring and Controlling phase, the estimate is in the range of +/- 15%.
- C. In the Closing phase, the estimate is in the range of +/- 15%.
- D. In the Planning phase, the estimate is in the range of +/- 50%.

Answer: A ([LEAVE A REPLY](#))

NEW QUESTION: 8

The following is a network diagram for a project.

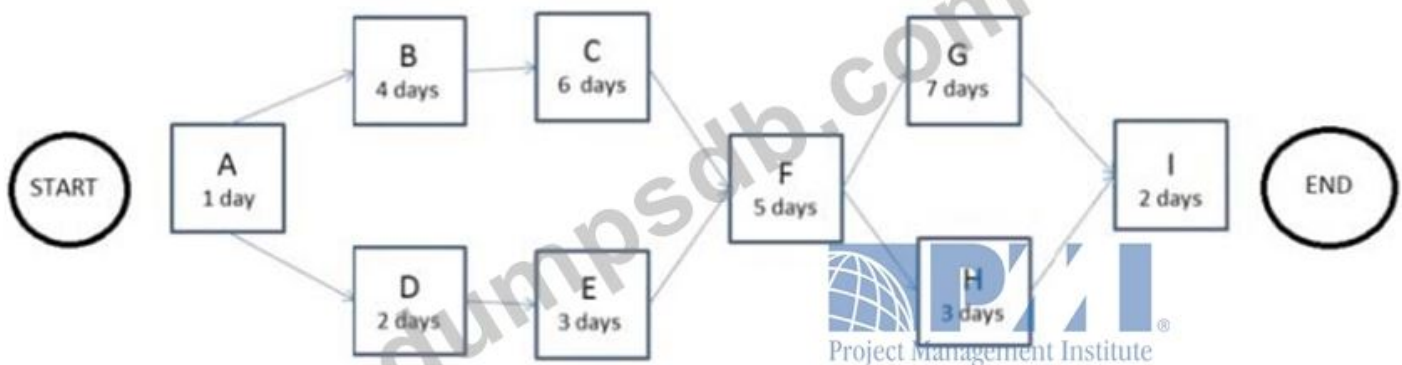

The free float for Activity H is how many days?

- A. 10
- B. 4
- C. 5
- D. 11

Answer: B ([LEAVE A REPLY](#))

NEW QUESTION: 9

A project manager has been assigned to a project where collaboration with the business is a critical key factor.

The project manager is not sure about which approach to use. A senior project manager has been assigned to help the project manager.

What advice should the senior project manager provide?

- A. Provide a project management template for the project manager to follow as a guide.
- B. Work with the project manager to develop a new approach that will bring benefits to the project.
- C. Establish a project management methodology that requires the customer to provide daily updates to the team.

D. Suggest using an agile approach since customer and team collaboration is critical for project success.

Answer: B ([LEAVE A REPLY](#))

NEW QUESTION: 10

You are managing a social health insurance project. You are in the testing phase of the project, and the customer has requested additional requirements. A change request has been initiated. What should you do first regarding this request?

- A. Document the change request and submit it for review by the change control board.
- B. Meet with your management to discuss the potential change
- C. Meet with the project sponsor to discuss the potential change
- D. Evaluate the change request

Answer: ([SHOW ANSWER](#))

NEW QUESTION: 11

What component of the project scope definition defines project exclusions?

- A. Project boundaries
- B. Project constraints
- C. Project assumptions
- D. Project objectives

Answer: A ([LEAVE A REPLY](#))

Section: Planning

NEW QUESTION: 12

In which of the project processes should one determine whether to obtain products and services from outside the organization?

- A. Plan purchases and acquisition
- B. Scope definition
- C. Risk identification
- D. Schedule development
- E. Activity sequencing

Answer: A ([LEAVE A REPLY](#))

NEW QUESTION: 13

An agile team is geographically separated across multiple continents, and the project manager is in the process of identifying the tools to manage the communication among the virtual teams Drag the appropriate tool on the left to each project task on the right

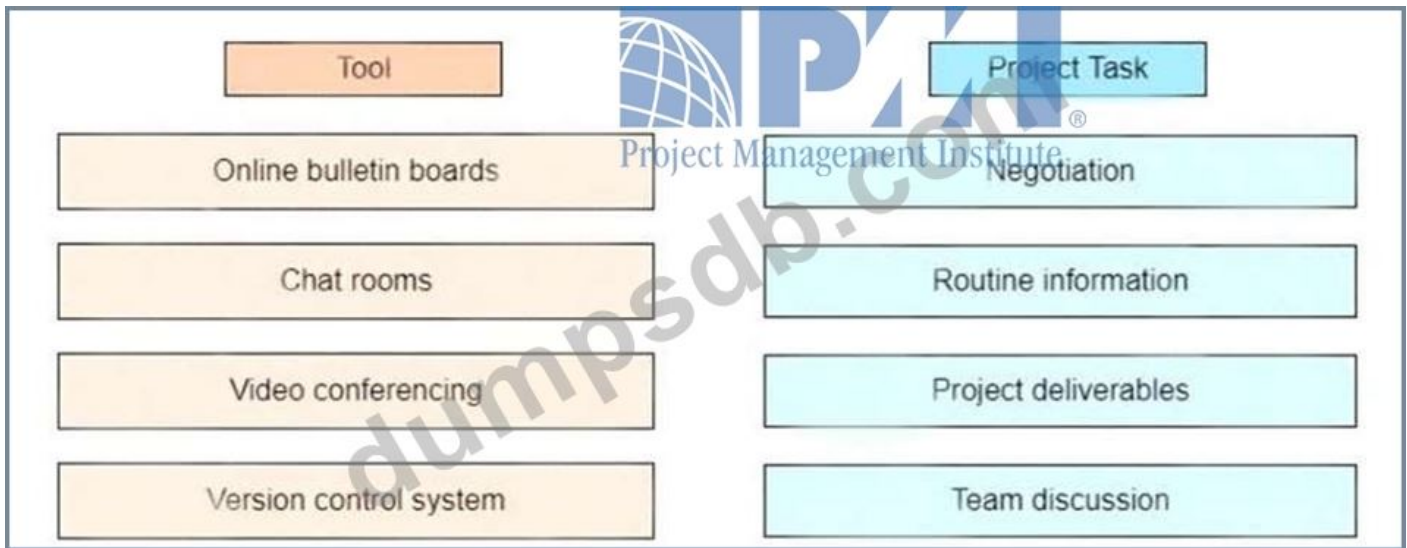

Answer:

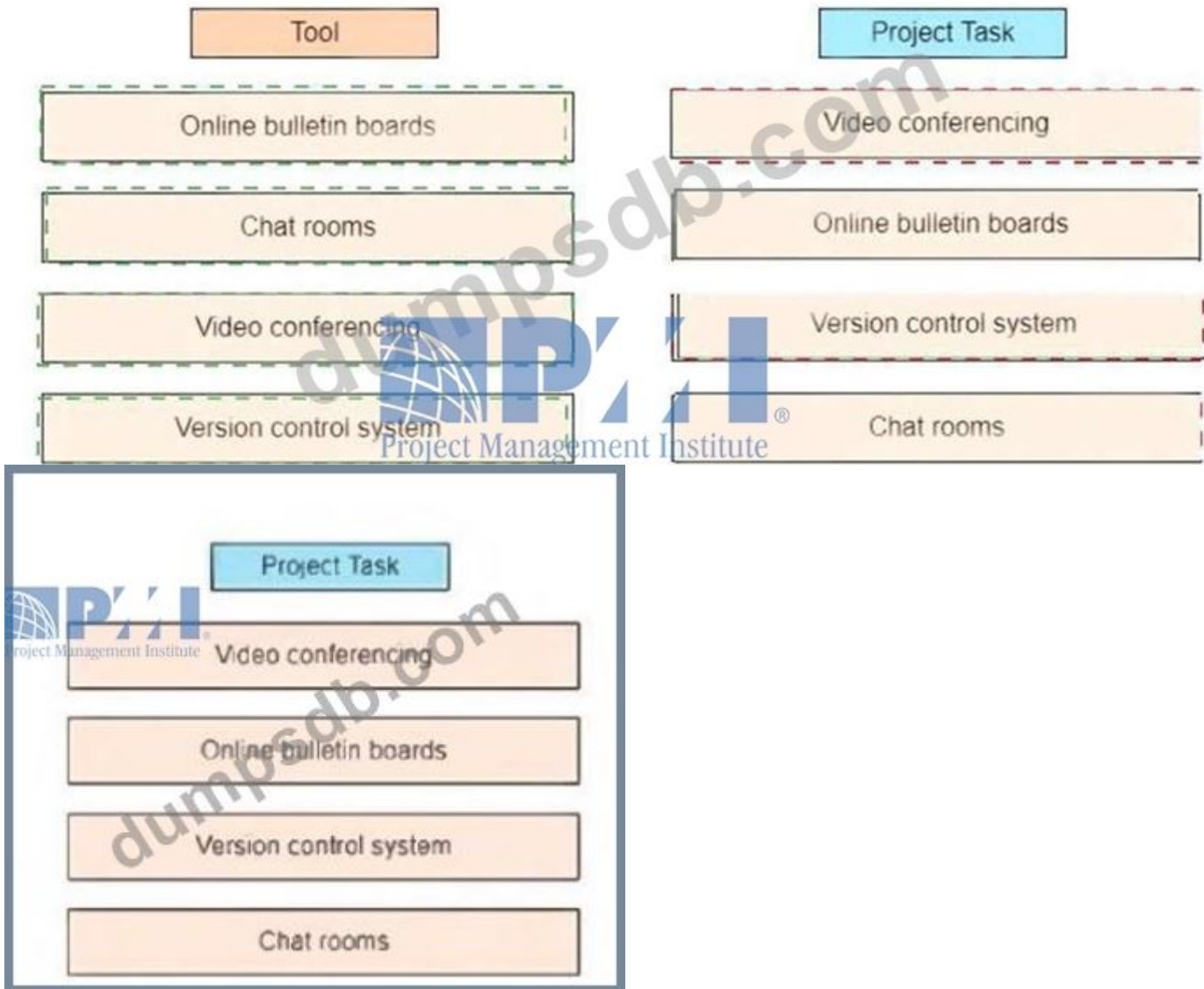

NEW QUESTION: 14

Procurement audits, negotiated settlements, and a records management system are tools and techniques used in which Procurement Management process?

- A. Close Procurements
- B. Administer Procurements
- C. Plan Procurements
- D. Conduct Procurements

Answer: ([SHOW ANSWER](#))

Section: Closing

NEW QUESTION: 15

While inspecting a contractor's progress, the project manager notices that the contractor is behind schedule.

The project manager speaks to the contractor who requests an extension.

What should the project manager do next?

- A. Verify the scope.
- B. Update the project schedule
- C. Issue a change request
- D. Conduct a performance review

Answer: ([SHOW ANSWER](#))

NEW QUESTION: 16

A project manager determines that a project will be behind schedule and over budget as its current pace. If tasks must be performed sequentially, what scheduling technique should be used to get the project schedule back on track?

- A. Fast tracking
- B. Critical path method (CPM)
- C. Schedule forecast
- D. Crashing

Answer: ([SHOW ANSWER](#))

Section: Executing

Valid PMP Dumps shared by TrainingQuiz.com for Helping Passing PMP Exam!

TrainingQuiz.com now offer the **newest PMP exam dumps**, the TrainingQuiz.com PMP exam **questions have been updated** and **answers have been corrected** get the **newest**

TrainingQuiz.com PMP dumps with Test Engine here: <https://www.trainingquiz.com/PMP-practice-quiz.html> (2045 Q&As Dumps, **40%OFF** Special Discount: **Exam-Tests**)

NEW QUESTION: 17

Which document defines how a project is executed, monitored and controlled, and closed?

- A. Strategic plan
- B. Project charter

- C. Project management plan
- D. Service level agreement

Answer: C ([LEAVE A REPLY](#))

Section: Planning

NEW QUESTION: 18

After formal client acceptance project deliverables were provided to the end users These users then identified a defect, for which the client holds the project manager responsible What could have prevented this misunderstanding'?

- A. A negotiation with the client on warranty terms and conditions
- B. Ensuring the client understood this was not part of the original requirement
- C. Proper project transition procedures
- D. Removal of project access to all team members after project closure

Answer: C ([LEAVE A REPLY](#))

NEW QUESTION: 19

A complete set of concepts, terms, and activities that make up an area of specialization is known as:

- A. program management
- B. a Knowledge Area
- C. portfolio management
- D. a Process Group

Answer: B ([LEAVE A REPLY](#))

NEW QUESTION: 20

To ease the workload on the acceptance testing team a key stakeholder request that intermediate project milestones be delivered in a sequence different than that outlined in the original project plan. What should the project manager do first?

- A. Inform all stakeholders of the request
- B. Update the project plan with the reordered intermediate program milestones..
- C. Recalculate the project's critical path to determine the impact of the request
- D. Issue a change request to document the request change.

Answer: C ([LEAVE A REPLY](#))

NEW QUESTION: 21

A project to develop a large hydropower plant is in the implementation phase and is managed using a hybrid approach. What should the project manager do to ensure full compliance of quality requirements during the execution phase?

- A. Plan quality management
- B. Continually survey the quality of the deliverable
- C. Analyze the quality requirements.

D. Set up quality policies and procedures

Answer: B ([LEAVE A REPLY](#))

NEW QUESTION: 22

A project manager meets with the project sponsor and customer, both of whom declare the project a success and agree to accept project deliverables. The sponsor is impressed that the project was completed on schedule and within budget, and wants the project manager to immediately assume a new, larger, and critically important project.

What should the project manager do next?

A. Ask the current project team to immediately begin work on the new project.

B. Verify that project deliverables conform to quality standards.

C. Organize a team celebration for the current project.

D. Archive all project documents for the current project.

Answer: D ([LEAVE A REPLY](#))

Section: Closing

NEW QUESTION: 23

What type of organization experiences the least amount of stress during project closeout?

A. Functional

B. Weak matrix

C. Strong matrix

D. Projectized

Answer: ([SHOW ANSWER](#))

Weak matrix organizational structures tend to experience the least amount of stress during the project closeout processes.

NEW QUESTION: 24

Which process involves defining, preparing, and coordinating all subsidiary plans and integrating them into a comprehensive plan?

A. Develop Project Management Plan

B. Plan Quality Management

C. Direct and Manage Project Work

D. Monitor and Control Project Work

Answer: ([SHOW ANSWER](#))

NEW QUESTION: 25

The zero duration of milestones in project planning occurs because milestones:

A. Are unpredictable and challenge the Plan Schedule Management process.

B. Occur at random times in the project plans.

C. Represent a moment in time such as a significant project point or event.

D. Represent both significant and insignificant points in the project and are difficult to anticipate.

Answer: C ([LEAVE A REPLY](#))

Section: Initiation

Explanation/Reference:

NEW QUESTION: 26

A project manager has been assigned a low-priority project that includes new team members with no previous formal project experience. The project team has requested deadline extensions for the first development increment twice already.

What should the project manager do to support the team?

- A. Escalate the impact on the schedule to the project sponsor.
- B. Create a change request to extend the project's duration and costs.
- C. Include buffer time in the schedule to absorb future delays.
- D. Provide feedback to the team using project performance evaluations.

Answer: C ([LEAVE A REPLY](#))

NEW QUESTION: 27

Which output of Project Cost Management consists of quantitative assessments of the probable costs required to complete project work?

- A. Earned value management
- B. Activity cost estimates
- C. Cost management plan
- D. Cost baseline

Answer: B ([LEAVE A REPLY](#))

NEW QUESTION: 28

The project velocity has recently slipped, and a decision was made to skip testing to increase the momentum and bring the project back on track. What will the project manager need to focus on as a result of this decision?

- A. Increased burn rate
- B. Increased cost
- C. Decreased efficiency
- D. Increased technical debt

Answer: D ([LEAVE A REPLY](#))

NEW QUESTION: 29

While developing a project's benefits management plan, a project manager receives input from some stakeholders that the project has very little value for the company. What should the project manager do next?

- A. Use organizational process assets.
- B. Review the business case with all stakeholders.
- C. Notify the sponsor of the conflicting stakeholder concerns.

D. Document the stakeholders' input in the stakeholder engagement plan.

Answer: (SHOW ANSWER)

Section: Monitoring and Controlling

NEW QUESTION: 30

Contract documentation are an input to the contract closure process. Which of the following are NOT included as part of the contract documentation?

- A. Seller response reports
- B. Invoices and payment records
- C. Contract changes
- D. Supporting schedules
- E. Contract file

Answer: (SHOW ANSWER)

NEW QUESTION: 31

A project manager is appointed to manage an infrastructure project that spans across several countries, including different time zones within a subregion. It is likely that most of the project team members will never meet, but they will have to collaborate to ensure deliverables are met. What should the project manager do to ensure good collaboration between the remote project team members?

- A. Plan a communication method and allow the project team members to virtually interact.
- B. Set the ground rules and identify a contingency plan in the risk register.
- C. Create a social media group platform for the team to create a supportive environment.
- D. Discuss the concerns with the project sponsor and modify the project charter to include more budget for interactions.

Answer: A (LEAVE A REPLY)

Valid PMP Dumps shared by TrainingQuiz.com for Helping Passing PMP Exam!

TrainingQuiz.com now offer the **newest PMP exam dumps**, the TrainingQuiz.com PMP exam **questions have been updated** and **answers have been corrected** get the **newest**

TrainingQuiz.com PMP dumps with Test Engine here: [https://www.trainingquiz.com/PMP-](https://www.trainingquiz.com/PMP-practice-quiz.html)

[practice-quiz.html](https://www.trainingquiz.com/PMP-practice-quiz.html) (2045 Q&As Dumps, **40%OFF Special Discount: Exam-Tests**)

NEW QUESTION: 32

A project manager is creating a program evaluation and review technique (PERT) diagram. A primary activity on the critical path has a most optimistic time of three weeks, a most pessimistic time of seven weeks, and a most likely time of five weeks.

What is the activity's expected time?

- A. 3 weeks

- B. 5 weeks
- C. 6 weeks
- D. 7 weeks

Answer: B (LEAVE A REPLY)

Section: Executing

NEW QUESTION: 33

Which provides the basic framework for managing a project?

- A. Project life cycle
- B. Work breakdown structure (WBS)
- C. Enterprise environmental factors
- D. Project initiation

Answer: A (LEAVE A REPLY)

Section: Planning

NEW QUESTION: 34

A local company is developing a new product and, for the first time, using a remote team for the programming tasks of features. The design for the product comes from the local team. During the third sprint review, the product owner has concerns about the project's outcomes. The remote development team is complaining that they do not clearly understand the requirements conveyed in the daily standup meetings.

How should the project manager address this situation?

- A. Review lessons learned from previous projects and organizational process assets (OPAs).
- B. Document the risk in the risk management plan and use contingency reserves to hire a local vendor.
- C. Evaluate and reassign the developing tasks to a local vendor who has worked on previous projects.
- D. Determine the communication needs, environment, and tools to get the message across.

Answer: D (LEAVE A REPLY)

NEW QUESTION: 35

During a group activity to identify an input to the Plan Procurement Management process, some participants disagree with the ranking of compliance-related items. What tool or technique should the project manager use to resolve this?

- A. Brainstorming
- B. Multicriteria decision analysis
- C. Nominal group technique
- D. Affinity diagram

Answer: (SHOW ANSWER)

NEW QUESTION: 36

Upon completion of a new shopping mall the project manager needs to determine if the project meets the planned success criteria To what should the project manager refer?

- A. Benefits management plan
- B. Project charter
- C. Scope management plan
- D. Project management plan

Answer: B ([LEAVE A REPLY](#))

NEW QUESTION: 37

All of the following statements are true regarding the communications management plan EXCEPT:

- A. The communications management plan is an output of the communications planning process
- B. The communications management plan should be formal and highly detailed
- C. The communications management plan is an input to the information distribution process
- D. The communications management plan provides information on stakeholder communication requirements and glossary of common terminology

Answer: ([SHOW ANSWER](#))

NEW QUESTION: 38

A retail company engages a new service provider to implement a replenishment system for its stores. The current system is built on old technology, fails to cater to new business processes, and performs slowly. User acceptance testing shows that the new system accommodates all business processes, but it is slower than the original.

The use of what tool or technique would have avoided this problem?

- A. Focus groups
- B. Benchmarking
- C. Interviews
- D. Statistical sampling

Answer: B ([LEAVE A REPLY](#))

Section: Monitoring and Controlling

NEW QUESTION: 39

Which of the following is a tool or technique of the Define Activities process?

- A. Rolling wave planning
- B. Precedence diagramming method (PDM)
- C. Alternatives analysis
- D. Parametric estimating

Answer: A ([LEAVE A REPLY](#))

Section: Closing

NEW QUESTION: 40

A new team member inquires about how much they need to learn about the organizational process assets (OPAs) residing on the company intranet. Another team member states they only need to know the basics. However, the project manager believes the team member should know everything regarding the OPAs.

What should the project manager do?

- A. Create a training schedule for the new team member to follow over the next few weeks.
- B. Clarify the relevance of reviewing the documentation on the intranet.
- C. Ask a senior team member to help the new team member navigate through all the documentation.
- D. Escalate the inquiry to the team member's functional manager.

Answer: B (LEAVE A REPLY)

NEW QUESTION: 41

A team of experts provides a project manager with different effort estimates for implementing a project's scope. What tool or technique should the project manager use to develop a project schedule?

- A. Three-point estimating
- B. Expert judgment
- C. Analogous estimating
- D. Focus groups

Answer: B (LEAVE A REPLY)

NEW QUESTION: 42

Which of the following is not true for Resource Leveling:

- A. Resource based scheduling method
- B. Project's Critical path may be altered
- C. Reverse resource allocation scheduling
- D. None of the other alternatives apply

Answer: D (LEAVE A REPLY)

All are true about Resource Levelling . Resource Levelling is another tool in Develop Schedule. Resource Levelling removes the peaks and valleys of resource allocation. This technique also examines resource over allocation and critical resource allocation. This technique lets the schedule and cost slip.

NEW QUESTION: 43

A measure of cost performance that is required to be achieved with the remaining resources in order to meet a specified management goal and is expressed as the ratio of the cost needed for finishing the outstanding work to the remaining budget is known as the:

- A. cost performance index
- B. earned value management (EVM)
- C. to-complete performance index

D. budget at completion (BAC)

Answer: ([SHOW ANSWER](#))

NEW QUESTION: 44

A project manager just started managing agile projects. The project manager realizes that due to the lack of a clear definition of project objectives and definition of done (DoD) their colleague's projects have had many difficulties. Sponsors keep asking for more features and the projects have yet to be completed. What should the project manager do to avoid these issues?

- A. Schedule meetings with key stakeholders to build the agile project charter and set clear expectations for the project.
- B. Arrange meetings to ensure every necessary task to complete the project is included in the project management plan.
- C. Convince the project sponsor to incorporate quality experts so the product can be tested and accepted as completed.
- D. Convince the product owner to approach the team and look for options to find a solution to the problem.

Answer: A ([LEAVE A REPLY](#))

NEW QUESTION: 45

Which statement is false? Progressive elaboration of project scope...

- A. ...signals a weak spot in the scope definition process, caused by incomplete contracts and specifications.
- B. ...when properly managed, integrates elaboration of project and deliverable specifications.
- C. ... means developing in steps. It not should be confused with scope creep.
- D. ...is a characteristic of projects that accompanies the concepts of temporary and unique.

Answer: A ([LEAVE A REPLY](#))

NEW QUESTION: 46

A project has been stopped during the execution phase because the construction methods are not in compliance with environmental regulations. The project manager was not aware of the environmental requirements of the project and now needs advice on how to deal with environmental compliance in future projects.

What should the project manager do to avoid a similar situation in future projects?

- A. Update the schedule every two weeks during the execution phase.
- B. Use expert judgment when dealing with environmental requirements.
- C. Plan to complete regulatory work within budget and on schedule.
- D. Collect project requirements during the initiation phase in every project.

Answer: ([SHOW ANSWER](#))

Valid PMP Dumps shared by TrainingQuiz.com for Helping Passing PMP Exam!

TrainingQuiz.com now offer the **newest PMP exam dumps**, the TrainingQuiz.com PMP exam **questions have been updated** and **answers have been corrected** get the **newest** TrainingQuiz.com PMP dumps with Test Engine here: <https://www.trainingquiz.com/PMP-practice-quiz.html> (2045 Q&As Dumps, **40%OFF** Special Discount: **Exam-Tests**)

NEW QUESTION: 47

The definition of when and how often the risk management processes will be performed throughout the project life cycle is included in which risk management plan component?

- A. Budgeting
- B. Risk categories
- C. Timing
- D. Methodology

Answer: (SHOW ANSWER)

NEW QUESTION: 48

You can use various estimating approaches to determine activity durations. When you have a limited amount of information available about your project, especially when in the early phases, the best approach to use is _____

- A. Bottom-up estimating
- B. Analogous estimating
- C. Reserve analysis
- D. Parametric analysis

Answer: (SHOW ANSWER)

Section: Mix Questions

Explanation:

Although limitations exist with all estimating approach, analogous estimating is often used when there is a limited amount of information for the project. It uses historical information and expert judgment.

NEW QUESTION: 49

Who is responsible for reviewing change requests and approving or rejecting the change requests?

- A. Project management office
- B. Project manager
- C. Change control board
- D. Project sponsor

Answer: (SHOW ANSWER)

NEW QUESTION: 50

A project manager is reviewing work performance data in preparation for the Close Project process. The data reveals that one of the deliverables was not accepted. The estimated work required to complete acceptance of the deliverable will delay the project completion date by two months.

What should the project manager do next?

- A. Update the schedule and perform the work
- B. Issue a change request for review by the change control board (CCB)
- C. Update the watch list in the risk register
- D. Allocate the contingency reserve to procure resources needed for completion

Answer: B ([LEAVE A REPLY](#))

NEW QUESTION: 51

A performance report indicates a variation in a product's specifications. The project manager calls an emergency meeting during which all team members offer suggestions for the possible cause of the variance. What tool or technique is the team using?

- A. Scatter diagram
- B. Matrix diagram
- C. Cause-and-effect diagram
- D. Root cause analysis (RCA)

Answer: D ([LEAVE A REPLY](#))

NEW QUESTION: 52

Which of the following is NOT a cost estimation tool or technique?

- A. Bottom-up
- B. Analogous
- C. Parametric
- D. Cost aggregation

Answer: D ([LEAVE A REPLY](#))

Cost Aggregation is used to build your budget, but it is not a tool for cost estimation. Bottom-up, Parametric, and Analogous estimation techniques are used for both cost and time estimates.

NEW QUESTION: 53

A project team is conducting a retrospective. The team wants to identify what had a positive impact on the velocity and keep doing it.

Click on the area that the team should focus on to identify good practices.



Answer:



NEW QUESTION: 54

A fixed-price-plus-incentive-fee (FPI) contract has a target cost of \$130,000, a target profit of \$15,000, a target price of \$145,000, a ceiling price of \$160,000, and a share ratio of 80/20. The actual cost of the project was \$150,000. How much profit does the seller make?

- A. \$10,000
- B. \$15,000
- C. \$0
- D. \$5,000

Answer: A ([LEAVE A REPLY](#))

Profit/Loss amount = Target Cost Actual Cost = 130000 150000 = -20000. Incentive Amount = 20% of (-20000) = -4000. Profit Amount = Target Profit + Incentive Amount = 15000 4000 = 11000. Total price = Actual Cost + Profit Amount = 150000 + 11000 = 161000 But there is a ceiling, so modified Total Price is 160000. So the Seller gets only 10000 (=160000 150000). Hence answer is A.

NEW QUESTION: 55

The Project Manager is involved in acquiring the project team on a highway expansion project. She is presently discussing salary, working hours, travel, and benefits. What is the key tool she is utilizing?

- A. Organizational chart
- B. Staffing management plan
- C. Negotiations
- D. Project team directory

Answer: ([SHOW ANSWER](#))

NEW QUESTION: 56

A project manager is assigned to a project to develop a mobile app. The sponsor explains that the application should do better than their closest competitor's app. The sponsor's expectation is that the team can be put together and start work immediately.

What should the project manager do?

- A. Start working on the resource management plan in order to identify the best team for the project.
- B. Review the competitor's app to understand the functionalities that the project scope should consider.
- C. Utilize expert judgment and organizational process assets (OPAs) to estimate the effort and budget.
- D. Define the project scope with the stakeholders and determine how formal acceptance will be obtained.

Answer: ([SHOW ANSWER](#))

NEW QUESTION: 57

The project manager has requested all expert team members to complete an anonymous questionnaire to identify possible risks. This is an example of a technique known as the:

- A. interview technique
- B. information gathering technique

- C. Delphi technique
- D. feedback technique

Answer: C (LEAVE A REPLY)

Section: Executing

NEW QUESTION: 58

The government sponsors a project to construct a new highway. The assigned project manager communicates to stakeholders that the project charter was approved. The project manager is working on the project management plan and receives an email from an environmental organization asking for the objectives and start date of the project.

What should the project manager do to address the situation?

- A. Conduct a stakeholder analysis and communicate to stakeholders accordingly.
- B. Respond to the email with the requested information.
- C. Conduct a brainstorming session with the stakeholders and the team
- D. Update the communications management plan accordingly.

Answer: D (LEAVE A REPLY)

Section: Executing

NEW QUESTION: 59

The vendor for a new IT data center project failed to follow the required cabling standards as stated in the requirements specification. The infrastructure manager and vendor were involved in an argument about the issue.

What should the project manager do to resolve and prevent additional arguments?

- A. Monitor the interactions between the vendor and infrastructure manager going forward.
- B. Host a meeting with the vendor and infrastructure manager to help resolve their disagreement.
- C. Escalate the issue to the sponsor so appropriate action can be taken.
- D. Instruct the vendor to correct the problem without additional arguments.

Answer: D (LEAVE A REPLY)

NEW QUESTION: 60

A project manager has just been assigned to a new project and has been given the approved project charter. The FIRST thing the project manager must do is:

- A. Begin work on a project management plan.
- B. Create a project scope statement.
- C. Confirm that all the stakeholders have had input to the scope.
- D. Analyze project risk.

Answer: C (LEAVE A REPLY)

NEW QUESTION: 61

A new project manager is assigned to a project midway through its implementation. During the first risk review meeting, the project manager notices that the version of the risk register used by the

project team members is different from the one the project manager is using What should the project manager have done to avoid this issue?

- A. Validated the project artifacts
- B. Validated the issue log
- C. Referred to the communications management plan
- D. Performed expert judgment

Answer: ([SHOW ANSWER](#))

Valid PMP Dumps shared by TrainingQuiz.com for Helping Passing PMP Exam!
TrainingQuiz.com now offer the **newest PMP exam dumps**, the TrainingQuiz.com PMP exam **questions have been updated** and **answers have been corrected** get the **newest** TrainingQuiz.com PMP dumps with Test Engine here: <https://www.trainingquiz.com/PMP-practice-quiz.html> (2045 Q&As Dumps, **40%OFF Special Discount: Exam-Tests**)

NEW QUESTION: 62

In a sender-receiver model, all the following are true except:

- A. Receiver is responsible for making sure that the information is completely received and understood
- B. Sender confirms that information is understood
- C. All the statement above are true
- D. Sender is responsible for making information clear, unambiguous and complete

Answer: C ([LEAVE A REPLY](#))

NEW QUESTION: 63

Which category of contracts are sellers legally obligated to complete, with possible financial damages if the project objectives are not met?

- A. Cost Plus Fixed Fee Contracts (CPFF)
- B. Fixed-price contracts
- C. Cost-reimbursable contracts
- D. Time and Material contracts (T&M)

Answer: B ([LEAVE A REPLY](#))

NEW QUESTION: 64

A project manager is working on a critical multinational project. The project is very complex and is planned to be completed in three years. The project manager is working with several contractors from countries with unstable economies, and the contractors are afraid that they will not be able to guarantee a fixed price for their services for the life of the project.

Which precautions should the project manager take into consideration?

- A. Register the risk and establish a procedure in the change management plan to handle these changes.
- B. Notify the sponsor about this and ask for a larger budget for any contingency.
- C. Inform the procurement manager and ask procurement to handle this with these vendors directly.
- D. Set a maximum price that cannot be exceeded for the extent of the project.

Answer: A ([LEAVE A REPLY](#))

Section: Initiation

NEW QUESTION: 65

What are the 5 kinds of power?

- A. Legitimate, expert, reward, political, and bargaining
- B. Legitimate, expert, reward, political, and punishment
- C. Legitimate, expert, reward, economic, and bargaining
- D. Legitimate, expert, reward, referent, and punishment

Answer: ([SHOW ANSWER](#))

Legitimate power is the kind of power you have when you tell someone who reports to you to do something. Expert power is when your opinion carries weight because people know that you know what you're talking about. Reward power is when you promise a reward for doing as you ask. Referent power is when people do what you say because of your association with somebody else. Punishment power is when people do what you say because they are afraid of the consequences.

NEW QUESTION: 66

Recognizing the importance of preparing a stakeholder management plan, you met with your team to obtain their buy in and to discuss it. You explained the key benefit of plan stakeholder management is to_____

- A. Determine appropriate strategies for a continual focus on identifying stakeholders throughout the life cycle
- B. Provide a clear plan that is actionable to interact with stakeholders to support the project's interests
- C. Develop appropriate management strategies to effectively engage stakeholders
- D. Plan a series of meetings to ensure stakeholders remain interested and to address their concerns

Answer: ([SHOW ANSWER](#))

Explanation/Reference:

Explanation:

While the plan stakeholder management process develops appropriate management strategies to effectively engage the stakeholders during the project life cycle, the key benefit of this process is to have a plan that is clear and actionable to interact with them to support the project's interests.

NEW QUESTION: 67

A project manager is managing multiple stakeholders. The project is behind schedule and reporting demands from management have increased. The project manager assesses the most efficient way to keep all stakeholders informed of the project's progress. What should the project manager use to keep stakeholders updated on work progress'?

- A. Benchmarking
- B. Burndown chart
- C. Sprint report
- D. Gantt chart

Answer: D (LEAVE A REPLY)

NEW QUESTION: 68

A project manager recording project risks discovers that, in the past, the company's purchasing department experienced delays when purchasing critical project inputs. The project manager identifies that if this risk materializes it will increase the schedule by 50 percent.

What should the project manager do?

- A. Reinforce the importance of this project to the purchasing department.
- B. Analyze the situation, and develop a response strategy with the team.
- C. Inform the sponsor, and execute the management reserve.
- D. Update the schedule to accommodate the delay of critical inputs.

Answer: B (LEAVE A REPLY)

Section: Executing

NEW QUESTION: 69

As an output from control communications, it may be necessary to update the_____

- A. Project schedule
- B. Forecasts
- C. Corporate policies, procedures, and processes
- D. Knowledge management system

Answer: B (LEAVE A REPLY)

Section: Mix Questions

Explanation:

Communications control often entails the need to update project documents, including forecasts, performance reports, and the issue log.

NEW QUESTION: 70

When are the most expensive defects most likely to be introduced into a product?

- A. When the quality management plan is being written
- B. When the product is being assembled
- C. When the product is being designed
- D. When the product is being reviewed by the customers

Answer: C (LEAVE A REPLY)

The most expensive defects are the ones introduced when the product is being designed. This is a little counterintuitive at first, but it really makes sense once you think about how projects are run. If your team introduces a defect into a product while it's being assembled, then they have to go back and fix it. But if there's a flaw in the design, then you have to halt production and go back and figure out all the things that flaw affected. You may have to order new parts, reassemble components, and maybe even go back and redesign the product from the ground up.

NEW QUESTION: 71

Which of the following procurement processes results in the awarding of a procurement contract?

- A. Administer Procurements
- B. Close Procurements
- C. Conduct Procurements
- D. Plan Procurements

Answer: C (LEAVE A REPLY)

Section: Executing

NEW QUESTION: 72

At the completion of a project phase, a previously unknown stakeholder complained that their deliverables for the phase were not met. What should the project manager have done to prevent this?

- A. Reviewed the stakeholder register to understand all stakeholder expectations.
- B. Interviewed stakeholders within other units in the organization
- C. Identified the stakeholder deliverables within the scope management plan
- D. Reviewed the quality management plan to ensure that such mistakes were minimized.

Answer: C (LEAVE A REPLY)

Section: Executing

NEW QUESTION: 73

As a project manager, you try to use empathic listening skills to help understand another person's frame of reference. In following this approach, you should_____

- A. Mimic the content of the message
- B. Probe, then evaluate the content
- C. Evaluate the content, then advise
- D. Rephrase the content and reflect the feeling

Answer: (SHOW ANSWER)

Section: Mix Questions

Explanation:

Empathic listening requires seeing the world the way the other person sees it, with the goal of understanding that person's views and feelings. Unlike sympathetic listening, empathic listening

contains no element of value judgment. It is essential to listen actively and effectively and to question and probe ideas to help ensure better understanding.

NEW QUESTION: 74

Which of the following statements correctly characterizes pull communication?

- A. It includes letters, memos, reports, emails, and faxes.
- B. It requires recipients to access communication content at their own discretion.
- C. It is the most efficient way to ensure a common understanding among all participants.
- D. It is primarily used when the volume of information to be transferred is minimal.

Answer: B (LEAVE A REPLY)

Section: Planning

NEW QUESTION: 75

You have been asked to submit a proposal for a project that has been put out for bid. First you attend the bidder conference to ask questions of the buyers and to hear the questions some of the other bidders will ask. Which of the following statements is true?

- A. Bidder conferences are a tool and technique of the Request Seller Responses process.
- B. Bidder conferences are an output of the Request Seller Responses process.
- C. Bidder conferences are a tool and technique of the Select Sellers process.
- D. Bidder conferences are an output of the Select Sellers process.

Answer: (SHOW ANSWER)

Bidder conferences are a tool and technique of the Request Seller Responses. Solicitation is where proposals are submitted by vendors and obtained by the organization.

NEW QUESTION: 76

Which of the following are included in cost control? (Choose all that apply.)

- A. Recording appropriate changes to the cost baseline.
- B. Preparing cost estimates.
- C. Monitoring cost performance.
- D. Informing stakeholders of changes.

Answer: (SHOW ANSWER)

Valid PMP Dumps shared by TrainingQuiz.com for Helping Passing PMP Exam!

TrainingQuiz.com now offer the **newest PMP exam dumps**, the TrainingQuiz.com PMP exam **questions have been updated** and **answers have been corrected** get the **newest** TrainingQuiz.com PMP dumps with Test Engine here: <https://www.trainingquiz.com/PMP-practice-quiz.html> (2045 Q&As Dumps, **40%OFF Special Discount: Exam-Tests**)

NEW QUESTION: 77

Which of the following correctly describes when organizations and stakeholders are willing to accept varying degrees of risk?

- A. Risk attitude
- B. Risk management
- C. Risk analysis
- D. Risk tolerance

Answer: D ([LEAVE A REPLY](#))

NEW QUESTION: 78

The project sponsor requested technical specifications for a project-related component. The project sponsor does not have the authorization to see the specifications, but insists on seeing them. What should the project manager do first in this situation?

- A. Create a stakeholder engagement plan to help the team formulate a response
- B. Provide the specifications to the project sponsor with some information removed
- C. Update the issue log to make the project team aware and to develop a strategy
- D. Meet with the project sponsor as soon as possible to discuss the matter further

Answer: D ([LEAVE A REPLY](#))

NEW QUESTION: 79

The project is going through Quality control. Which of the following are used to validate that the output is in compliance with the specifications of the work?

- A. Inspection
- B. Checklists
- C. Rework
- D. Acceptance decisions

Answer: ([SHOW ANSWER](#))

Section: Mix Questions

NEW QUESTION: 80

In general, attempts to smooth out period to period resources will _____ the scheduled time and _____ project costs.

- A. Increase, increase or decrease.
- B. Decrease, increase.
- C. Decrease, decrease.
- D. Increase, increase
- E. Increase, decrease.

Answer: ([SHOW ANSWER](#))

NEW QUESTION: 81

The following chart contains information about the tasks in a project.

Task	PV	AC	EV
1	10,000	10,000	10,000
2	10,000	8,000	10,000
3	10,000	8,000	8,000
4	9,000	12,000	10,000
5	10,000	12,000	12,000
6	10,000	10,000	12,000
7	12,000	12,000	10,000
8	10,000	8,000	9,000
9	12,000	10,000	11,000

Based on the chart, what is the schedule variance (SV) for Task 8?

- A. -1,000
- B. -2,000
- C. 2,000
- D. 1,000

Answer: ([SHOW ANSWER](#))

NEW QUESTION: 82

Quality metrics are an output of which process?

- A. Plan Quality
- B. Perform Qualitative Risk Analysis
- C. Perform Quality Control
- D. Perform Quality Assurance

Answer: ([SHOW ANSWER](#))

NEW QUESTION: 83

You are the project manager for a cable service provider. Your project team is researching a new service offering. They have been working together for quite some time and are in the performing stage of Develop Project Team. This stage of Develop Project Team is similar to which of the following?

- A. Achievement Theory
- B. Self-actualization
- C. Smoothing

D. Hygiene Theory

Answer: B (LEAVE A REPLY)

The performing stage is similar to Maslow's self-actualization. Both involve team members at the peak of performance, concerned with doing good and being the best.

NEW QUESTION: 84

You are the project manager for a major logistics installation project and must obtain specific services from local sources external to your project. Your subcontracts administrator has told you to prepare a product or service description, which is referenced in a _____

- A. Project statement of work
- B. Contract scope statement
- C. Request for proposal
- D. Contract

Answer: A (LEAVE A REPLY)

Explanation/Reference:

Explanation:

The project statement of work describes in a narrative form the products, services, or results that the project will deliver. It references the product scope description as well as the business need and strategic plan.

NEW QUESTION: 85

Your project management office implemented a project management methodology that emphasizes the importance of integrated change control. It states that change requests can occur in all the following forms EXCEPT _____

- A. Indirect
- B. Legally mandated
- C. Informal
- D. Internally initiated

Answer: C (LEAVE A REPLY)

Explanation/Reference:

Explanation:

Change requests are an input to the perform integrated change control process. Although occurring in many forms, they must be formal requests developed within the context of a change control system consisting of documented procedures.

NEW QUESTION: 86

A company is implementing a project with team members located in different countries and time zones.

Individual performance is satisfactory, but the team's performance as a whole is low, especially in terms of group activities.

What should the project manager do?

- A. Review and reassign team assignments.
- B. Facilitate communication and team building.
- C. Review and update the communications management plan.
- D. Negotiate for new team members.

Answer: B ([LEAVE A REPLY](#))

NEW QUESTION: 87

A project is behind schedule due to an incorrectly estimated task on the critical path. What should the project manager do?

- A. Ask a team member to explain to the customer why the task was incorrectly estimated.
- B. Explain the issue to the customer and advise them on exactly how much of a delay is expected.
- C. Analyze whether fast tracking or crashing techniques will bring the schedule on track before informing the customer.
- D. Inform the customer when the committed timelines are crossed and plan workarounds. i

Answer: B ([LEAVE A REPLY](#))

NEW QUESTION: 88

A project manager acquires a subject matter expert (SME) from a different country. The SME is unable to collocate with the rest of the team.

What should the project manager do?

- A. Update the communications management plan and share it with the project team.
- B. Add a risk to the risk register to address communication issues.
- C. Use a local, but less qualified, SME.
- D. Have all team members work remotely as a virtual team.

Answer: ([SHOW ANSWER](#))

Section: Executing

Explanation/Reference:

NEW QUESTION: 89

If the most likely duration of an activity is five weeks, the best-case duration is two weeks, and the worst-case duration is 14 weeks, how many weeks is the expected duration of the activity?

- A. Seven
- B. Six
- C. Five
- D. One

Answer: B ([LEAVE A REPLY](#))

NEW QUESTION: 90

The Project Manager is working with the sponsor to attain formal acceptance on the infrastructure project deliverables. The customer is saying that seven of the deliverables are not meeting project

goals, and are unusable in their present form. Upon reviewing documentation, the sponsor explains to the Project Manager that the requirements are not accurate, to meet the needs for which the project was planned.

What part of the Planning process did this problem occur?

- A. Creating the Work Breakdown Structure
- B. Scope Definition
- C. Scope Control
- D. Scope Verification

Answer: B (LEAVE A REPLY)

NEW QUESTION: 91

You're managing a project with a schedule performance index (SPI) of 1.07 and a cost performance index (CPI) of 0.94. How would you BEST describe this project?

- A. The project is behind schedule and over its budget
- B. The project is ahead of schedule and within its budget
- C. The project is behind schedule and within its budget
- D. The project is ahead of schedule and over its budget

Answer: D (LEAVE A REPLY)

When you're looking at CPI and SPI numbers, remember: lower = loser. If your CPI is below 1.0, then your project is over its budget. If the SPI is below 1.0, then the project is behind schedule. In this case, the project is ahead of schedule, since its SPI is above 1.0. But it's over its budget, because it's got a CPI that's below 1.0.

Valid PMP Dumps shared by TrainingQuiz.com for Helping Passing PMP Exam!

TrainingQuiz.com now offer the **newest PMP exam dumps**, the TrainingQuiz.com PMP exam **questions have been updated** and **answers have been corrected** get the **newest**

TrainingQuiz.com PMP dumps with Test Engine here: <https://www.trainingquiz.com/PMP-practice-quiz.html> (2045 Q&As Dumps, **40%OFF Special Discount: Exam-Tests**)

NEW QUESTION: 92

Exhibit A is an example of which of the following types of Sequence Activities?

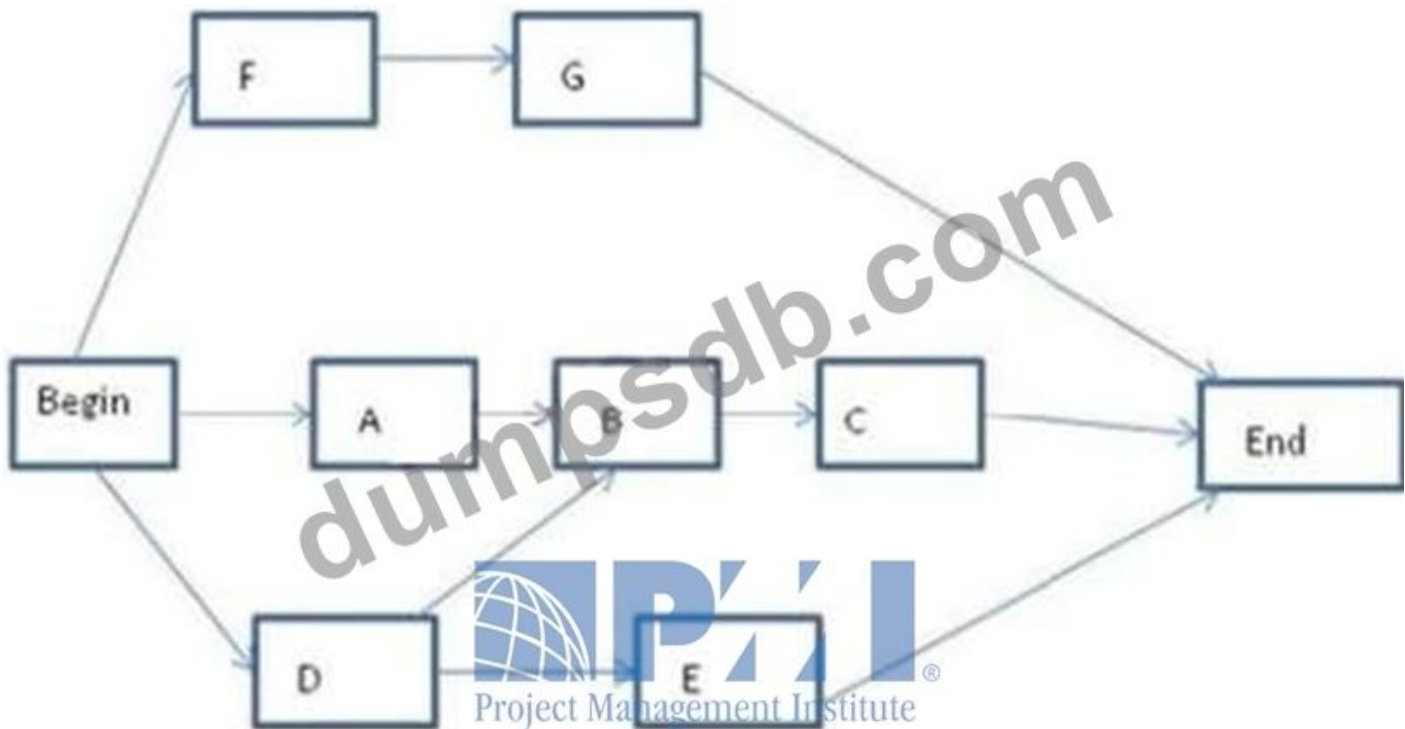

- A. Activity-on-arrow diagramming
- B. Precedence diagramming
- C. Project schedule network diagramming
- D. Mathematical analysis diagramming

Answer: C ([LEAVE A REPLY](#))

Section: Closing

NEW QUESTION: 93

In project management, a temporary project can be:

- A. Completed without planning
- B. A routine business process
- C. Long in duration
- D. Ongoing to produce goods

Answer: C ([LEAVE A REPLY](#))

Section: Initiation

NEW QUESTION: 94

Risk management is defined as the art and science of _____ risk factors throughout the life cycle of a project.

- A. Identifying, analyzing and responding to
- B. Reviewing, monitoring and managing
- C. Researching, reviewing and acting on
- D. Identifying, reviewing and avoiding

Answer: A ([LEAVE A REPLY](#))

NEW QUESTION: 95

Assigned risk ratings are based upon:

- A. Expert judgment.
- B. Risk probability and impact assessment.
- C. Revised stakeholders' tolerances.
- D. Root cause analysis.

Answer: B ([LEAVE A REPLY](#))

NEW QUESTION: 96

The process of identifying and documenting relationships among the project activities is known as:

- A. Sequence Activities.
- B. Define Activities.
- C. Control Schedule.
- D. Develop Schedule.

Answer: ([SHOW ANSWER](#))

NEW QUESTION: 97

For a project to be successful, the project team must do which of the following?

- A. Complete the project in sequential phases.
- B. Overlook minor stakeholders.
- C. Select the appropriate processes required to meet the project objective.
- D. Produce ongoing repetitive products, services, or results.

Answer: C ([LEAVE A REPLY](#))

NEW QUESTION: 98

Which of the following is an input to the Plan Risk Responses process?

- A. Risk urgency assessment
- B. Organizational process assets
- C. Risk register
- D. Schedule management plan

Answer: ([SHOW ANSWER](#))

Section: Executing

NEW QUESTION: 99

What can a responsibility assignment matrix (RAM) eliminate?

- A. Confusion on who is responsible for doing what
- B. Confusion on who is on the team
- C. Confusion on what order activities come in
- D. Confusion on how long the activities are

Answer: ([SHOW ANSWER](#))

NEW QUESTION: 100

Which process uses occurrence probability and impact on project objectives to assess the priority of identified risks?

- A. Qualitative risk analysis
- B. Risk identification
- C. Quantitative risk analysis
- D. Risk management planning

Answer: A ([LEAVE A REPLY](#))

NEW QUESTION: 101

Which document describes the procurement item in sufficient detail to allow prospective sellers to determine if they are capable of providing the products, services, or results?

- A. Request for quote
- B. Procurement statement of work
- C. Procurement management plan
- D. Request for proposal

Answer: B ([LEAVE A REPLY](#))

NEW QUESTION: 102

A lead project manager for an agile project needs to prioritize requirements define the scope of the initial product and deliver the approved scope in a series of multiple versions. What should the project manager do next?

- A. Determine the expected benefits of each requirement to maximize the overall business value
- B. Work with the product owner to evaluate and prioritize the requirements
- C. Ask the lead developer to run a meeting with the stakeholders to agree on an ordered list
- D. Prioritize the requirements based on the hierarchical level of the requesting stakeholders

Answer: A ([LEAVE A REPLY](#))

NEW QUESTION: 103

During the last two iterations of a project, one of the team members had low performance. The project manager conducted two feedback sessions with the team member and escalated the issue to the resource manager and project sponsor, but there has been no improvement.

What should the project manager do next?

- A. Provide feedback to the resource at the sprint review.
- B. Review this obstacle during the daily standup meeting.
- C. Request a new resource to execute the activities.
- D. Escalate the situation again to the project sponsor.

Answer: C ([LEAVE A REPLY](#))

NEW QUESTION: 104

You are a project manager working on a software development project. Your project team begins to address the project work, technical decisions, and the project management approach- If team members are not collaborative or open to differing ideas, which stage of the Tuchman ladder has your team just entered?

- A. Forming
- B. Norming
- C. Performing
- D. Storming

Answer: ([SHOW ANSWER](#))

NEW QUESTION: 105

Which of the following processes involves analyzing activity sequences, activity duration, and resource requirements, to develop the project schedule?

- A. Activity sequencing
- B. Activity definition
- C. Activity duration estimation
- D. Scope definition
- E. Schedule development

Answer: E ([LEAVE A REPLY](#))

NEW QUESTION: 106

Due to a budget issue, the project team decides to use low-cost equipment with higher testing uncertainty to reduce cost. However, the test results are unstable and are creating discrepancies. One of the team members is aware of the situation and proposes to use high-resolution equipment with lower test uncertainty to increase the testing quality.

How should the project manager respond to this proposal?

- A. Reject the proposal due to budget constraints and follow the quality management plan.
- B. Accept the proposal because the high-resolution equipment produces precise test results with lower test uncertainty.
- C. Evaluate the proposal to determine if the high-resolution equipment produces precise test results with lower test uncertainty.
- D. Accept the proposal because budget is not an issue when quality assurance is taken into consideration.

Answer: C ([LEAVE A REPLY](#))

Section: Executing

Valid PMP Dumps shared by TrainingQuiz.com for Helping Passing PMP Exam!

TrainingQuiz.com now offer the **newest PMP exam dumps**, the TrainingQuiz.com PMP exam **questions have been updated** and **answers have been corrected** get the **newest**

TrainingQuiz.com PMP dumps with Test Engine here: <https://www.trainingquiz.com/PMP-practice-quiz.html> (2045 Q&As Dumps, **40%OFF Special Discount: Exam-Tests**)

NEW QUESTION: 107

During a project's initiation phase, the project manager reviews the business case and finds that information is incomplete. What should the project manager do?

- A. Add an information gap to the risk register.
- B. Review the project statement of work (SOW) to create the project charter.
- C. Revise the business case to narrow the project scope and create the project charter.
- D. Review the business case with the sponsoring organization to confirm that the project aligns with business needs.

Answer: D (LEAVE A REPLY)

Section: Initiation

NEW QUESTION: 108

You are managing a design project that would provide design drawings to your customer. The requirements of this project were not clearly defined in the beginning, and there would need to be many changes based on customer feedback as the project evolves. You elaborate the work of the project to the level of detail you know at the time. Which of the following techniques would be the most helpful while defining activities for the project?

- A. Extreme programming
- B. Rolling wave planning
- C. Just in time
- D. Decomposition

Answer: B (LEAVE A REPLY)

NEW QUESTION: 109

You are the project manager at a manufacturer of electronic components. Your company had been a long time market leader in electronic components distribution industry. However, in recent years, the Internet has transformed the competitive landscape. As a result company's market share has been eroding. Hence, your current project involves implementing the company's internet strategies to best exploit these altered dynamics and increase the company's market share. Unfortunately, your project is plagued by frequent changes to the project charter. Who should be the primary person responsible for deciding whether the changes to the project charter are necessary?

- A. Project manager
- B. Project sponsor
- C. Project team
- D. Change control board
- E. Stakeholders

Answer: B (LEAVE A REPLY)

NEW QUESTION: 110

Contract negotiations are NOT required when _____

- A. A company uses sealed bids
- B. There is a sole source procurement
- C. A competitive range is established
- D. A two-step process is used

Answer: A (LEAVE A REPLY)

Explanation/Reference:

Explanation:

When using the sealed bid method, competitive market forces determine the price, and the award goes to the lowest bidder, provided all other terms and conditions of the contract are met.

NEW QUESTION: 111

You are responsible for ensuring that your seller's performance meets contractual requirements.

For effective contract control, you should _____

- A. Hold a bidders' conference
- B. Establish the appropriate contract type
- C. Implement the contract change control system
- D. Develop a statement of work

Answer: C (LEAVE A REPLY)

Section: Mix Questions

Explanation

Explanation:

Contract change control entails ensuring that contract changes are properly approved and that everyone who needs to know is made aware of such changes.

NEW QUESTION: 112

You are the project manager for a software company that develops sports-based video games. You have been assigned to develop a new 3D interactive basket ball video game. You have just completed the development of the project scope management plan. Which of the following processes did you just complete?

- A. Scope planning
- B. Develop preliminary project scope statement
- C. Cope definition
- D. Scope verification
- E. Scope control

Answer: A (LEAVE A REPLY)

NEW QUESTION: 113

Which of the following strategic considerations often results in project authorization?

- A. Customer requests and/or issue resolution
- B. Stakeholder expectations and/or strategic opportunity (business need)
- C. Technological advancement and/or senior executive request
- D. Market demand and/or legal requirements

Answer: D (LEAVE A REPLY)

Section: Executing

Explanation

NEW QUESTION: 114

A marketing campaign is being built to support a new product at a utility company. The company doesn't have data on what volume to expect from the marketing campaign and the associated advertising. This data is important because it will help drive the number of employees needed in the department so customers' needs can be met. The Project Manager remembers that a similar project was by a company his company acquired. He begins to review data from this project. This is a best example of what?

- A. Historical information
- B. Lessons learned
- C. Constraints
- D. Assumptions

Answer: A (LEAVE A REPLY)

Section: Mix Questions

NEW QUESTION: 115

The project manager is having difficulty communicating with one of the team members The team member recently attended a training course and has been training other team members in a new agile technique However sometimes the team member is forceful in pushing ideas even if other team members are uncomfortable What personality indicators should the project manager consider when determining what communication style to use with this team member?

The image shows a drag-and-drop interface for a personality indicator quiz. It contains two sections. The first section is titled "Drag The Personality Indicator #1 To The Team Member" and has three boxes: "Introverted (I)", "Team Member", and "Extroverted (E)". The second section is titled "Drag The Personality Indicator #2 To The Team Member" and has three boxes: "Judging (J)", "Team Member", and "Perceiving (P)". There is a large watermark "dumpsdb.com" across the image.

Answer:



NEW QUESTION: 116

During Risk identification sessions, you and your team identified more than 150 risks for your project. You are afraid that evaluating each of these risks quantitatively will cost you an enormous amount of time, while not all of them are really relevant and important enough to justify such a measure. What should you do next?

- A. Assess the potential impact of each risk qualitatively and further analyze only those risks with high impact.
- B. Assess the probability of each risk qualitatively and further analyze only those risks with high probability.
- C. Use Qualitative risk analysis in order to prioritize risks for further action, such as Quantitative risk analysis.
- D. Identify Risk triggers where possible. Analyze only those risks quantitatively for which no trigger could be found.

Answer: C (LEAVE A REPLY)

NEW QUESTION: 117

All of the following are true regarding the Quality Planning process except for which one?

- A. The tools and techniques of this process are cost-benefit analysis, benchmarking, DOE, COQ, and additional quality planning tools.
- B. Changes to the product as a result of meeting quality standards might require cost or schedule adjustments.
- C. DOE is a tool and technique of this process that provides statistical analysis for changing product or process elements one at a time to optimize the process.
- D. This is one of the key processes performed during the Planning process group and during the development of the project management plan.

Answer: C (LEAVE A REPLY)

Design of experiments is a tool and technique of the Quality Planning process that provides statistical analysis for changing key product or process elements all at once (not one at a time) to optimize the process.

NEW QUESTION: 118

Which type of contract is a hybrid of both a cost-reimbursable and a fixed-price contract?

- A. Time and Material Contract (T&M)
- B. Cost Plus Award Fee Contract (CPAF)
- C. Firm-Fixed -Price Contract (FFP)
- D. Cost Plus Incentive Fee Contract (CPIF)

Answer: A ([LEAVE A REPLY](#))

NEW QUESTION: 119

A project manager has made a change to the project. What should she do NEXT?

- A. Request change control board involvement.
- B. Assign resources.
- C. Revise the project management plan and/or project documents.
- D. Evaluate impact.

Answer: (SHOW ANSWER)

NEW QUESTION: 120

In the below path convergence example, if the odds of completing activities 1, 2, and 3 on time are 50 percent, 50 percent, and 50 percent, what are the chances of starting activity 4 on day 6?

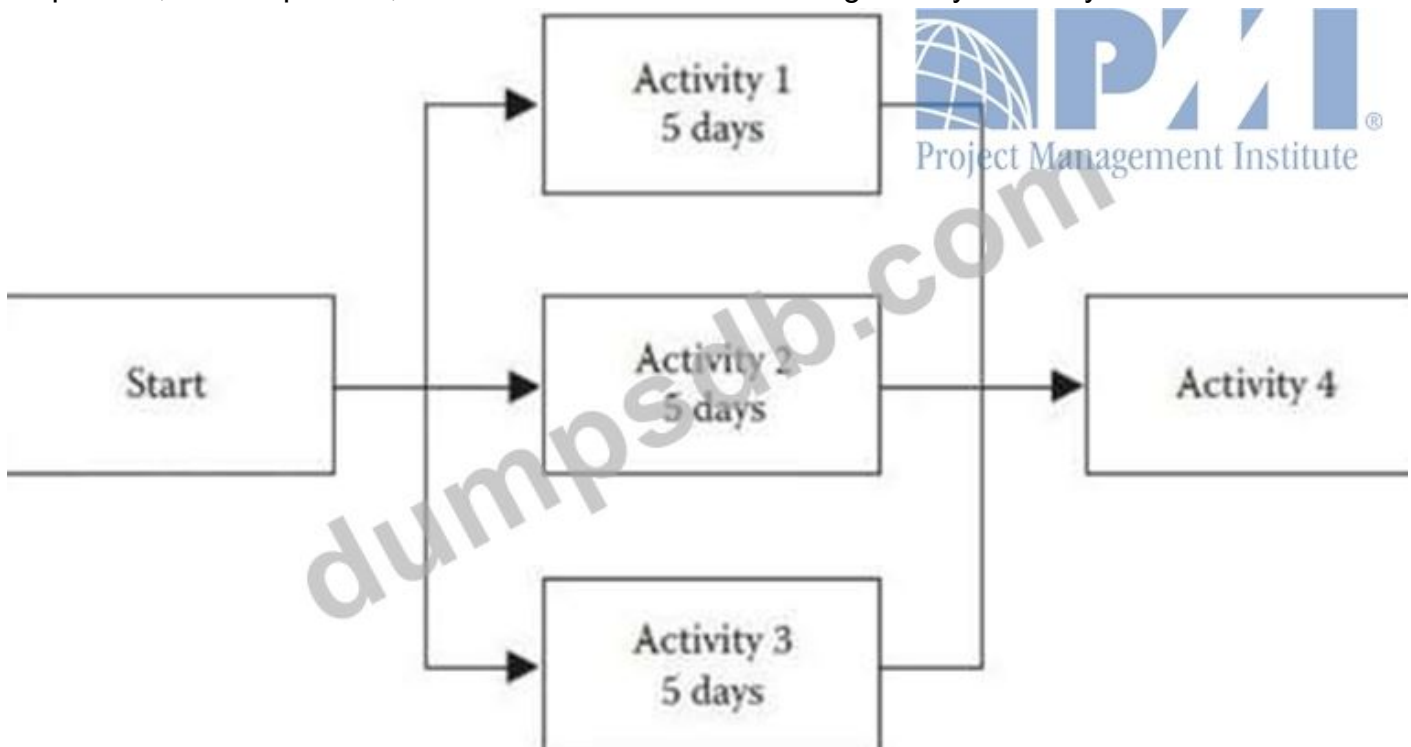

- A. 10 percent
- B. 13 percent
- C. 40 percent
- D. 50 percent

Answer: (SHOW ANSWER)

Section: Mix Questions

Explanation:

Probability (starting activity 4 on day 6) $= (0.5)^3$
 $= 0.125$ or 13%

NEW QUESTION: 121

You are the project manager at a leading manufacturer of consumer electronics, personal computers and peripherals. Unfortunately, your company is facing a rapidly maturing market characterized by consolidation and commoditization. Hence you have been assigned a project to drive growth and profit by integrating an online CRM (customer relationship management) solution. Industry benchmarks suggest the CRM solution should generate \$100-\$300M in bottom the benefits.

You've determined the following information so far: Activity X has an early start of day3, early finish of day6, and a late finish of day10. Activity Y is being performed by resource that had been very difficult to obtain. The CPI of the project is 0.8 and the SPI is 1.2. Based on the information above, which of the following areas should cause the MOST concern?

- A. Float
- B. Cost
- C. Quality
- D. Schedule
- E. Resource

Answer: ([SHOW ANSWER](#))

Valid PMP Dumps shared by TrainingQuiz.com for Helping Passing PMP Exam!

TrainingQuiz.com now offer the **newest PMP exam dumps**, the TrainingQuiz.com PMP exam **questions have been updated** and **answers have been corrected** get the **newest** TrainingQuiz.com PMP dumps with Test Engine here: <https://www.trainingquiz.com/PMP-practice-quiz.html> (2045 Q&As Dumps, **40%OFF Special Discount: Exam-Tests**)

NEW QUESTION: 122

Expectancy theory as applied to project management implies that:

- A. None of the other alternatives apply
- B. Employees will work hardest for those project goals which are accompanied by high levels of authority for the individual team members
- C. The team will work the hardest on those goals that are clearly explained by the project manager
- D. Team members will work hardest for those project goals that also bring satisfaction to personal goals
- E. The more rewards that the project manager provides, the better the performance of the team

Answer: D ([LEAVE A REPLY](#))

NEW QUESTION: 123

During a demonstration of their latest deliverable for a new solution being developed a vendor showed the client a new software module that would meet the client's needs better and improve the outcome of the project The new software module, which was not included in the original statement of work (SOW), costs US\$20 000 and would eliminate the need for US\$22,000 of testing work The client has decided that they would like to have the new module How should the project manager proceed1?

- A.** Tell the vendor that the change cannot be made because it is not in alignment with the procurement plan
- B.** Tell the vendor to go ahead with the new module because it costs less and has no impact on the schedule
- C.** Initiate a change request and inform the vendor that the client wishes to go ahead: subject to approval
- D.** Initiate this change from the vendor, and inform the sponsor about the decrease in cost

Answer: ([SHOW ANSWER](#))

NEW QUESTION: 124

You are a project manager responsible for constructing a new sports arena in preparation for upcoming Olympics. Construction begins on a project over a year ago. Stakeholders of the project want a status report on the performance of the project to the date. You have obtained the following measurement:

BAC=500, ETC=200, PV=500, AC=200, EV=300, CPI=1.5

You believe the type of variances that have occurred on the project to date to be atypical, and expect these variances to continue. Based on the information above what will be the VAC for the project?

- A.** 333.33
- B.** 100
- C.** 400
- D.** 133.33
- E.** 166.67

Answer: **E** ([LEAVE A REPLY](#))

NEW QUESTION: 125

You are a project manager for Laurel's Theater Productions. Your new project is coming in over budget and requires a cost change through the cost change control system. You know all of the following statements are true regarding Cost Control except for which one?

- A.** Changes are reflected in the cost baseline.
- B.** Performance is monitored to detect variances.
- C.** Changes are monitored and reflected in the project scope.
- D.** Changes are monitored so that inappropriate changes do not get into the cost baseline.

Answer: ([SHOW ANSWER](#))

Cost Control tracks project performance to detect variances and reflect them in the cost baseline. It's also used to prevent inappropriate changes from getting into the cost baseline.

NEW QUESTION: 126

A project manager is working on a software development project. A team member complains that since the project tasks are very simple, there is no reason to perform quality control. The project manager understands that removing the quality management plan from the project will also help to save money, which is important to the customer. What should the project manager do?

- A. Develop the quality management plan, as quality is as equally important as cost and schedule management.
- B. Get confirmation from management that the team member has enough experience to build software without quality control.
- C. Register starting the project without a quality management plan as a risk, and allocate the budget savings to the management reserve.
- D. Ask the customer to order an external quality audit after accepting the project deliverable, and decrease the budget of the project.

Answer: A ([LEAVE A REPLY](#))

NEW QUESTION: 127

Completion of the _____ scope is measured against the plan.

- A. Project
- B. Product
- C. Baseline
- D. Technical

Answer: ([SHOW ANSWER](#)**)**

NEW QUESTION: 128

A supplier is hired to provide information security services for a project. The supplier has decided not to provide this service any longer since they have not been paid on time. Their services are critical and this decision will affect the outcome of the project.

What should the project manager do to address this issue?

- A. Penalize the supplier according to the contract's service level agreement (SLA)
- B. Inform the relevant stakeholders of this challenge and seek their support
- C. Negotiate the payments with the supplier and remind them of their long-term association
- D. Hire another information security supplier and incentivize them for speedy delivery

Answer: C ([LEAVE A REPLY](#))

NEW QUESTION: 129

Identifying major deliverables, deciding if adequate cost estimates can be developed, and identifying tangible components of each deliverable are all part of which of the following?

- A. Work breakdown structure

- B. Organizational breakdown structure
- C. Resource breakdown structure
- D. Bill of materials

Answer: A ([LEAVE A REPLY](#))

Section: Planning

NEW QUESTION: 130

When should Lessons learned be organized?

- A. At the end of the project during closing.
- B. During the project lifecycle and at the end.
- C. Lessons learned can be organized when there is time available.
- D. After the end of the project at a project post-mortem meeting.

Answer: B ([LEAVE A REPLY](#))

NEW QUESTION: 131

Which type of management focuses on ensuring that projects and programs are reviewed to prioritize resource allocation?

- A. Project
- B. Functional
- C. Program
- D. Portfolio

Answer: D ([LEAVE A REPLY](#))

Section: Executing

NEW QUESTION: 132

Identifying interrelationships and potential overlap between stakeholders is useful to the project manager as he or she works with stakeholders. It should be documented as part of the _____

- A. Stakeholder register
- B. Stakeholder management strategy
- C. Stakeholder management plan
- D. Stakeholder engagement assessment matrix

Answer: C ([LEAVE A REPLY](#))

Explanation/Reference:

Explanation:

The stakeholder management plan identifies the management strategies required to effectively engage stakeholders. It includes, among other things, the identified interrelationships and potential overlap between stakeholders. This information is invaluable especially if some stakeholders are resistant or negative to the project and also in determining the level of frequency of desired interaction and communications requirements.

NEW QUESTION: 133

Which of the following tool/ technique are unplanned responses to risks that were previously unidentified?

- A. Workarounds
- B. Project risk reviews
- C. Risk response audits
- D. Corrective actions
- E. Risk database

Answer: A ([LEAVE A REPLY](#))

NEW QUESTION: 134

After a functional team delivers a product the project manager uses statistical sampling and inspection to determine if the product performs as expected What is the output of this process?

- A. Quality audit report
- B. Project scope statement
- C. Verified deliverables
- D. Quality metrics

Answer: D ([LEAVE A REPLY](#))

NEW QUESTION: 135

_____ sometimes, called risk symptoms or warning signs, are indications that a risk has occurred or is about to occur.

- A. Delphi technique
- B. Risk
- C. Assumption analysis
- D. Triggers

Answer: ([SHOW ANSWER](#))

NEW QUESTION: 136

Which of the following is the process of identifying the specific actions to be performed to produce the project deliverables?

- A. Estimate Activity Durations
- B. Sequence Activities
- C. Define Activities
- D. Activity Attributes

Answer: C ([LEAVE A REPLY](#))

Section: Initiation

Valid PMP Dumps shared by TrainingQuiz.com for Helping Passing PMP Exam!
TrainingQuiz.com now offer the **newest PMP exam dumps**, the TrainingQuiz.com PMP exam **questions have been updated** and **answers have been corrected** get the **newest** TrainingQuiz.com PMP dumps with Test Engine here: <https://www.trainingquiz.com/PMP-practice-quiz.html> (2045 Q&As Dumps, **40%OFF Special Discount: Exam-Tests**)

NEW QUESTION: 137

A Project with a total funding of \$70,000 finished with a BAC value of \$60,000.

What term can best describe the difference of \$10,000?

- A. Management Contingency Reserve
- B. Cost Variance
- C. Schedule Variance
- D. Management Overhead

Answer: A (LEAVE A REPLY)

The difference between the Cost Baseline and Funding requirement at Project completion is Management Contingency Reserve. BAC represents the revised Cost baseline for the project. So Management Contingency Reserve is true.

NEW QUESTION: 138

In a multinational project, stakeholders are in different time zones. The project manager has regular project update meetings with the stakeholders. However, a group of stakeholders who has never attended project update meetings is complaining to the project sponsor that they know very little about the project.

What should the project manager do?

- A. Change the meeting time to the working time zones of the stakeholders who are complaining.
- B. Discuss the issue with all stakeholders and work on a communications management plan to meet all stakeholder requirements.
- C. Record the regular project update meeting and share it with all stakeholders after the meeting is completed.
- D. Ensure that the stakeholders who are complaining are present for the next project update meetings.

Answer: B (LEAVE A REPLY)

NEW QUESTION: 139

The risk register is initiated in the Risk Identification process and further updated in the Qualitative Risk analysis and Quantitative Risk analysis processes. Which of the following are NOT risk register updates as part of the Quantitative Risk Analysis process?

- A. Trends in quantitative risk analysis results
- B. Probabilistic analysis of the project
- C. Prioritized list of qualified risks

- D. Risk categorization
- E. Probability of achieving cost and time objects

Answer: D ([LEAVE A REPLY](#))

NEW QUESTION: 140

The project is in a balanced matrix environment. There are significant challenges with the schedule and resource constraints of the project. Project personnel have been complaining to the Project Manager about the environment. In this type of environment, who controls the resources?

- A. Senior management
- B. Project Manager
- C. Functional Manager
- D. Project Coordinator

Answer: C ([LEAVE A REPLY](#))

NEW QUESTION: 141

A company is using a predictive approach for the development of a particular component as defined in the scope management plan. Due to regularly changing regulatory requirements, the development team has requested to utilize agile approaches. What should the project manager do about the development team's request?"

- A. Analyze the requirements that will need to be addressed under the requested method
- B. Escalate the request for additional financial resources
- C. Ask the project sponsor to obtain approval for implementation of the new approach
- D. Forward the request to the project management office (PMO) to amend the organizational process assets

Answer: D ([LEAVE A REPLY](#))

NEW QUESTION: 142

Which of the following process is involved in making needed information available to project stakeholders in a timely manner?

- A. Performance reporting
- B. Communications planning
- C. Manage stakeholders
- D. Information distribution

Answer: D ([LEAVE A REPLY](#))

NEW QUESTION: 143

Which input will be used when tasked with developing the human resource plan?

- A. Project management plan
- B. Activity resource requirements
- C. Resource calendar
- D. Project staff assignments

Answer: B ([LEAVE A REPLY](#))

Section: Planning

NEW QUESTION: 144

During risk analysis for a building renovation project, it is discovered that the building contains toxic materials that must be removed. What should the project manager do to mitigate this risk using the risk transference strategy?

- A. Hire a contractor to perform the work.
- B. Train personnel how to remove the toxic materials and then perform the work.
- C. Ask the client to remove the toxic materials and exclude this work from the contract.
- D. Increase the management reserves to address the potential impact of additional time and cost.

Answer: A ([LEAVE A REPLY](#))

NEW QUESTION: 145

The charter for a project to build a new financial reward system for the sales division is approved. What should the project manager do now?

- A. Collect scope requirements.
- B. Develop the scope baseline.
- C. Develop the project scope statement.
- D. Prepare the scope management plan.

Answer: D ([LEAVE A REPLY](#))

NEW QUESTION: 146

An input to the Control Quality process is:

- A. Deliverables
- B. Quality control measurements
- C. Activity attributes
- D. Enterprise environmental factors

Answer: ([SHOW ANSWER](#))

NEW QUESTION: 147

Which of the following lists contain processes that are included within Project Procurement Management?

- A. Plan purchases and acquisitions, acquire project team, contract approval, select sellers
- B. Plan purchases and acquisitions, request seller responses, select sellers, schedule control
- C. Plan purchases and acquisitions, plan contracting, request seller responses, select sellers
- D. Plan purchases and acquisitions, acquire project team, request seller responses, select sellers

Answer: C ([LEAVE A REPLY](#))

NEW QUESTION: 148

A project is defined in the PMBOK as:

- A. A process of considerable scope that implements a plan
- B. A group of ideas managed in a coordinated way to obtain a desired outcome
- C. A collection of activities with a beginning and an end
- D. A temporary endeavor undertaken to create a unique product or service

Answer: ([SHOW ANSWER](#))

A temporary endeavor undertaken to create a unique product or service

NEW QUESTION: 149

A project team must implement a solution to replace a company's legacy system by adding new modules to newly deployed software. A key stakeholder recommends another product that has better functionality than the deployed software.

What should the project manager do to resolve this?

- A. Work with stakeholders to assess and map the key benefits and outcomes.
- B. Create a project charter to document ideas and suggestions.
- C. Review lessons learned from previous projects to determine better stakeholder engagement guidelines.
- D. Ask vendors to provide quotes for both implementations.

Answer: A ([LEAVE A REPLY](#))

Section: Executing

NEW QUESTION: 150

As a project manager on a software development project you are accountable for maintaining the integrity of the performance measurement baselines. This includes making sure that approved changes to the schedule and cost are reflected in the project plan. However, you also make sure that only changes to the project scope affect the performance measurement baselines. This is an example of:

- A. Performance measurement
- B. Overall change control
- C. Scope change control
- D. Configuration management

Answer: B ([LEAVE A REPLY](#))

NEW QUESTION: 151

The following is a network diagram for a project.

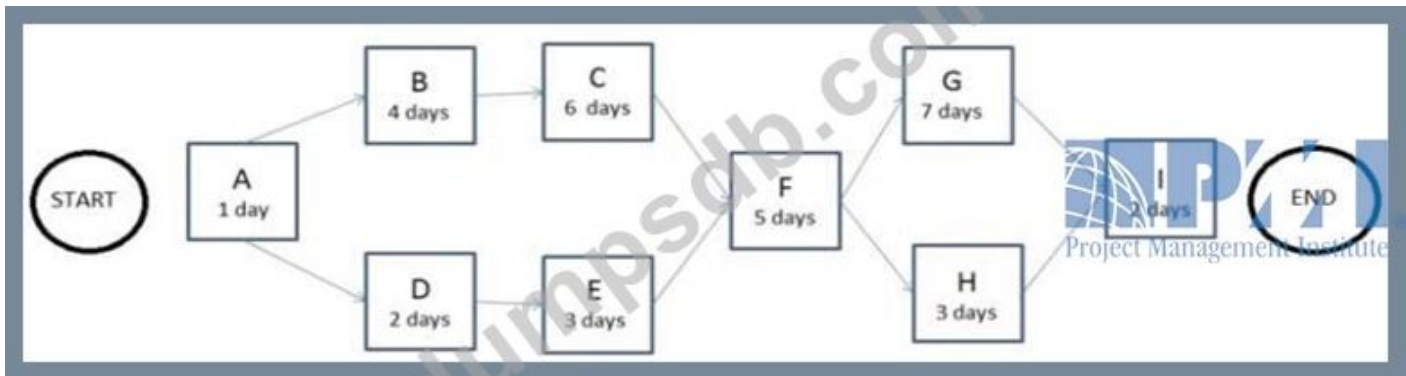

The free float for Activity H is how many days?

- A. 11
- B. 10
- C. 4
- D. 5

Answer: ([SHOW ANSWER](#))

Valid PMP Dumps shared by TrainingQuiz.com for Helping Passing PMP Exam!

TrainingQuiz.com now offer the **newest PMP exam dumps**, the TrainingQuiz.com PMP exam **questions have been updated** and **answers have been corrected** get the **newest** TrainingQuiz.com PMP dumps with Test Engine here: <https://www.trainingquiz.com/PMP-practice-quiz.html> (2045 Q&As Dumps, **40%OFF Special Discount: Exam-Tests**)

NEW QUESTION: 152

The total of the planned value (PV) is also known as:

- A. work breakdown structure (WBS).
- B. earned value baseline.
- C. performance measurement baseline (PMB).
- D. schedule target.

Answer: C ([LEAVE A REPLY](#))

NEW QUESTION: 153

You are the controller on your project. Your project manager has requested that you provide him with a forecast of project costs for the next 12 months. He needs this information to determine if the budget should be increased or decreased on this major construction project. In addition to the usual information sources, which of the following should you also consider?

- A. Cost estimates from similar projects
- B. Long-range weather forecasts
- C. Existing change requests
- D. The WBS

Answer: ([SHOW ANSWER](#))

NEW QUESTION: 154

Which tool or technique used in the Control Procurements process can be conducted during the execution of the project to verify compliance with deliverables?

- A. Inspection and audits
- B. Procurement documents
- C. Risk register
- D. Estimate budget

Answer: A (LEAVE A REPLY)

NEW QUESTION: 155

The team you have organized for your new project consists of three people who will work full-time and five people who will support the project on a part-time basis. All team members know one another and have worked together in the past. To ensure a successful project start-up, your first step should be to _____

- A. Meet with each team member individually to discuss assignments
- B. Prepare a responsibility assignment matrix and distribute it to each team member
- C. Distribute the project plan and WBS to the team
- D. Hold a project kickoff meeting

Answer: D (LEAVE A REPLY)

Explanation/Reference:

Explanation:

An indispensable tool in project management, the kickoff or launch meeting is held at the outset of the project and is designed to get the project rolling. The meeting provides the opportunity not only to present the project charter and discuss the project's goals and objectives but also to establish rapport among team members.

NEW QUESTION: 156

You are a project manager for Picture Shades, Inc. It manufactures window shades that have replicas of Renaissance-era paintings on the inside for hotel chains. Picture Shades is taking its product to the home market, and you're managing the new project. It will offer its products at retail stores as well as on its website. You're developing the project schedule for this under-taking and have determined the critical path. Which of the following statements is true?

- A. You calculated the early and late start dates, the early and late finish dates, and float times for all activities.
- B. You calculated the optimistic, pessimistic, and most likely duration times and the float times for all activities.
- C. You calculated the activity dependency and the optimistic and pessimistic activity duration estimates.
- D. You calculated the most likely start date and most likely finish dates, float time, and weighted average estimates.

Answer: A ([LEAVE A REPLY](#))

The CPM calculates a single early and late start date and a single early and late finish date for each activity. Once these dates are known, float time is calculated for each activity to determine the critical path. The other answers contain elements of PERT calculations.

NEW QUESTION: 157

You are managing a moderately risky project. You have done well identifying risks and assessing them both on the probability of the risk event occurring and on the level of impact that the risk could have on your project if it actually occurred. But to help with a "next" level of qualitative risk analysis, you could use a _____

- A. Risk priority assessment
- B. Risk quality assessment
- C. Risk urgency assessment
- D. Quantitative risk analysis

Answer: C ([LEAVE A REPLY](#))

Explanation/Reference:

Explanation:

Risks that may occur in the near-term need urgent attention. The purpose of the risk urgency assessment is to identify those risks that have a high likelihood of occurring. Assessing risk urgency can be combined with the risk ranking that is determined from the probability and impact matrix for a final risk severity rating.

NEW QUESTION: 158

Forecasting human resource requirements necessitates making predictions about both the supply and demand of human resources. Which of the following is not a method used to forecast the demand for human resources?

- A. Regression Analysis
- B. PERT Charts
- C. Time Series Analysis
- D. Delphi Method
- E. Staffing Tables

Answer: ([SHOW ANSWER](#))

NEW QUESTION: 159

An earthquake occurs at the site of a manufacturing plant construction project. This affects the entire project budget.

What type of reserve analysis should the project manager consider?

- A. Contingency
- B. Project
- C. Baseline
- D. Management

Answer: A ([LEAVE A REPLY](#))

NEW QUESTION: 160

A project manager developed the scope management plan for a new line of adaptive clothing. The designs and materials were approved, but when the prototypes were delivered they were less durable than expected.

What should the project manager have done to avoid this?

- A. Fully documented the product requirements
- B. Clearly defined the requirements traceability matrix
- C. Utilized quality control measures
- D. Performed a risk analysis

Answer: ([SHOW ANSWER](#))

Section: Monitoring and Controlling

NEW QUESTION: 161

Which of the following statements are true regarding the critical path method?

- A. The critical path method calculates the optimistic, pessimistic, and most likely float/ slack times for each activity
- B. The critical path method calculates the optimistic, pessimistic, and most likely duration times for each activity
- C. The critical path method calculates the early start, early finish, late start, late finish dates, and float times for each activity
- D. The critical path method calculates the early start, early finish, late start, late finish dates, and weighted averages for each activity

Answer: C ([LEAVE A REPLY](#))

NEW QUESTION: 162

Which of the following are true regarding project scope management?

- A. Scope definition involves creating a project scope management plan that document how the project scope will be defined and controlled
- B. Scope verification involves subdividing the major project deliverables into small more manageable components
- C. Scope planning involves developing a detailed project scope statement as a basis of future project decision
- D. None of the statements are correct
- E. Scope control involves formalizing the acceptance of project deliverables

Answer: D ([LEAVE A REPLY](#))

NEW QUESTION: 163

The project is nearing completion. The team is involved in a lot of different activities to close the project. They are in the process of grouping together various documents associated with financial

records, contracts, internal project documentation, and client-related documentation. What are they in the process of creating?

- A. Project Closure
- B. Contract File
- C. Lessons learned
- D. Archives

Answer: D ([LEAVE A REPLY](#))

Section: Mix Questions

NEW QUESTION: 164

You are managing a contact management software project and senior management has come to you with a fast breaking project that could make the company have a significant market share boost. According to your current project schedule, your current project is on pace to be completed in six weeks. What is the best response you can tell senior management?

- A. Implementing crashing and fast tracking to complete your current project ahead of schedule so you can start immediately on this project
- B. Telling senior management that you will consider the project once it has a charter
- C. Managing both projects as requested by senior management
- D. Assigning the Functional Manager on the project to finish the current project

Answer: ([SHOW ANSWER](#))

NEW QUESTION: 165

The basis of identification for current or potential problems to support later claims or new procurements is provided by:

- A. Procurement audits.
- B. Work performance information.
- C. A risk urgency assessment.
- D. The scope baseline.

Answer: B ([LEAVE A REPLY](#))

NEW QUESTION: 166

The amount of time that an activity can be delayed from its early start without delaying the project end date is called:

- A. Float
- B. Negative Float
- C. c and b
- D. Total Float

Answer: ([SHOW ANSWER](#))

Valid PMP Dumps shared by TrainingQuiz.com for Helping Passing PMP Exam!
TrainingQuiz.com now offer the **newest PMP exam dumps**, the TrainingQuiz.com PMP exam **questions have been updated** and **answers have been corrected** get the **newest** TrainingQuiz.com PMP dumps with Test Engine here: <https://www.trainingquiz.com/PMP-practice-quiz.html> (2045 Q&As Dumps, **40%OFF** Special Discount: **Exam-Tests**)

NEW QUESTION: 167

What should the project manager use to compare different suppliers and rate their proposals?

- A. Qualified seller lists
- B. Bid documents
- C. Evaluation criteria
- D. Bidder conferences

Answer: (SHOW ANSWER)

NEW QUESTION: 168

A project manager is assigned to a new project to deliver a product at the end of the year. The project manager was informed by the vendor that a core component could not be shipped on time, which will impact the schedule. What should project manager do next to minimize the impact on the project?

- A. Review and update the issue log and determine if any alternative components can be offered
- B. Replace the vendor with a new vendor who can offer the component on time
- C. Schedule a meeting with all stakeholders to extend the project deadline
- D. Add an item to the next status review to make stakeholders aware of the vendor issue.

Answer: (SHOW ANSWER)

NEW QUESTION: 169

Your project team has identified all the risks on the project and has categorized them as high, medium, and low. The "low" risks are placed on which one of the following for monitoring?

- A. Threat list
- B. Low risk list
- C. Watch list
- D. Low impact list

Answer: (SHOW ANSWER)

Explanation/Reference:

Explanation:

Even low-priority risks must be monitored. A watch list is used to ensure such risks are tracked for continued monitoring.

NEW QUESTION: 170

A project team delivered a critical deliverable to the customer. The customer complained that the maintenance manual was not included.

What should the project manager do next?

- A. Submit a change request to include the manual.
- B. Add the needed manual and update the risk log.
- C. Review the stakeholder engagement plan.
- D. Review the terms and conditions of the contract.

Answer: D ([LEAVE A REPLY](#))

NEW QUESTION: 171

On what is project baseline development established?

- A. Estimated project cost and schedule
- B. Revised project cost and schedule
- C. Actual project cost and schedule
- D. Approved product requirements

Answer: A ([LEAVE A REPLY](#))

NEW QUESTION: 172

The project management office (PMO) assigns a project manager who specializes in hybrid approaches to a predictive project that is off track from both the cost and schedule perspectives. The project runs into further delays as the project manager is ramping up on the project. The stakeholders and ask senior management to replace the project manager.

How should the project manager approach this situation?

- A. Escalate the stakeholder issue to the management team and ask for help with resolving the conflict.
- B. Meet with the stakeholders to understand their concerns and define an action plan to resolve issues.
- C. Socialize with the stakeholders to better understand their needs and reset expectations.
- D. Continue to work on the project until the stakeholders and management come to a decision.

Answer: B ([LEAVE A REPLY](#))

NEW QUESTION: 173

A no-cost settlement sometimes is used _____

- A. To close out a successful contract
- B. In lieu of formal termination procedures
- C. When buyer property has been furnished under the contract
- D. When such an arrangement is acceptable to one of the parties involved

Answer: B ([LEAVE A REPLY](#))

Explanation/Reference:

Explanation:

A no-cost settlement can be used in lieu of formal termination procedures when the seller has indicated that such an arrangement is acceptable, no buyer property has been furnished under the contract, no payments are due the seller, no other obligations are outstanding, and the product or service can be readily obtained elsewhere.

NEW QUESTION: 174

You are managing a critical project with virtual teams located in eight countries. Virtual teams that work on the same project but are not collocated at the same site. Managing virtual teams has unique advantages, such as being able to use special expertise on a project team even when the expert is not in the same geographic area. All of the team members globally communicate using email. What kind of communication method is this?

- A. Pull communication
- B. Interactive communication
- C. Vertical communication
- D. Push communication

Answer: ([SHOW ANSWER](#))

NEW QUESTION: 175

On the WBS, the first level of decomposition may be displayed by using all the following EXCEPT _____

- A. Phases of the project life cycle
- B. Subcomponents
- C. Major deliverables
- D. Project organizational units

Answer: ([SHOW ANSWER](#))

Section: Mix Questions

Explanation:

The WBS includes all work needed to be done to complete the project. The organizational breakdown structure (OBS) includes the organizational units responsible for completing the work.

NEW QUESTION: 176

A project needs to be outlined as a phased approach for multiple product lines with a review gate at the end of each phase. To ensure consistency for this hybrid delivery, what should the project manager do?

- A. Get agreement from stakeholders on high-level deliverables and requirements.
- B. Request the project management office (PMO) to review the initial plan
- C. Ask subject matter experts (SMEs) to provide a detailed plan for each phase.
- D. Commit to a detailed global plan from the initiation phase.

Answer: A ([LEAVE A REPLY](#))

NEW QUESTION: 177

An audit was conducted on a project during close out. The issue log could not be located in the project management information system (PMIS).

What should the project manager do to prevent this from becoming a nonconformance?

- A. Review the taxonomy of the document system for the excluded documents.
- B. Refer to the responsible, accountable, consult, and inform (RACI) chart to establish the responsible person for the specific documents.
- C. Assign a project administrator to search for the missing documents.
- D. Revise the project management plan to include the missing documents.

Answer: A ([LEAVE A REPLY](#))

Section: Closing

NEW QUESTION: 178

During the course of a project the project manager's immediate director is communicating directly with the client to approve changes without the project manager's knowledge. This is causing confusion in the project team where the scope is changing in the background, but only being mentioned in project meetings. How should the project manager handle this?

- A. Communicate directly with the director and inform them of the communications management plan.
- B. Discuss the issues with the project team and let them know that the project manager will handle scope changes.
- C. Review the stakeholder engagement plan and put in place any existing actions accordingly.
- D. Communicate directly with the client stating that any scope changes must go through the project manager.

Answer: ([SHOW ANSWER](#))

NEW QUESTION: 179

Which of the following techniques is used during Control Scope?

- A. Cost-benefit analysis
- B. Variance analysis
- C. Reserve analysis
- D. Stakeholder analysis

Answer: B ([LEAVE A REPLY](#))

Section: Executing

NEW QUESTION: 180

A project manager is asked to select a contract type for a new software development project that has complete, detailed requirements. Which is the BEST contract to choose?

- A. Cost plus fixed fee (CPFF)
- B. Time and material (T&M)
- C. Cost reimbursable (CR)
- D. Fixed price (FP)

Answer: D (LEAVE A REPLY)

NEW QUESTION: 181

In the beginning of project execution, the project manager finds out that a key resource will be unavailable for two weeks which could cause a delay to the schedule What should the project manager do first?

- A. Ask human resources (HR) for a replacement, and update the nsk register
- B. Update the resource management plan and resource allocation chart accordingly
- C. Update the schedule to reflect the project's changes in duration
- D. Assign the tasks to another resource, and ask the resource to work double shifts

Answer: B (LEAVE A REPLY)

Valid PMP Dumps shared by TrainingQuiz.com for Helping Passing PMP Exam!
TrainingQuiz.com now offer the **newest PMP exam dumps**, the TrainingQuiz.com PMP exam **questions have been updated** and **answers have been corrected** get the **newest** TrainingQuiz.com PMP dumps with Test Engine here: <https://www.trainingquiz.com/PMP-practice-quiz.html> (2045 Q&As Dumps, **40%OFF Special Discount: Exam-Tests**)

NEW QUESTION: 182

Feature 1	Feature 2	Feature 3	Feature 4	Feature 5	Feature 6
10 story points	5 story points	5 story points	10 story points	10 story points	5 story points

An agile team has sized all of the features for the release. Using the table above, how many sprints will it take to complete this release if the team is expecting to have a velocity of 10 story points per sprint?

- A. 1
- B. 4
- C. 6
- D. 95

Answer: D (LEAVE A REPLY)

NEW QUESTION: 183

Which type of analysis is used as a general management technique within the Plan Procurements process?

- A. Risk assessment analysis
- B. Make or buy analysis
- C. Contract value analysis

D. Cost impact analysis

Answer: ([SHOW ANSWER](#))

Section: Initiation

Explanation

NEW QUESTION: 184

Which of the following is a complete set of indexed contract documentation, including the closed contract?

- A. Procurement package
- B. Procurement management plan
- C. Negotiated settlements
- D. Procurement file

Answer: D ([LEAVE A REPLY](#))

NEW QUESTION: 185

Which is not an example of formal communication?

- A. Contract
- B. email
- C. Project status report
- D. Status meeting

Answer: B ([LEAVE A REPLY](#))

Communication via email is not considered a formal communication.

NEW QUESTION: 186

A marketing team's project manager is working on improving an employee engagement project. The marketing team will be creating materials, events and messages to increase engagement. How should the project manager approach stakeholder engagement*?

- A. Classify stakeholders according to their influence on project work
- B. Use brainstorming to define the stakeholder engagement plan
- C. Hold a kick-off meeting to gain employee support
- D. Create a power/interest grid to identify stakeholders' levels of authority

Answer: B ([LEAVE A REPLY](#))

NEW QUESTION: 187

Unplanned responses to emerging risks that were earlier accepted is also called a(an)

- A. Update to risk identification checklist
- B. Workaround
- C. Update to risk response plan
- D. Corrective Action

Answer: B ([LEAVE A REPLY](#))

NEW QUESTION: 188

What type of project structure is a hierarchically organized depiction of the resources by type?

- A. Work breakdown structure (WBS)
- B. Resource breakdown structure (RBS)
- C. Organizational breakdown structure (OBS)
- D. Project breakdown structure (PBS)

Answer: ([SHOW ANSWER](#))

NEW QUESTION: 189

The most common form of written project communication is

- A. Letters and memos
- B. Bulletin boards
- C. Publications
- D. All of the other alternatives apply
- E. Reports

Answer: ([SHOW ANSWER](#))

NEW QUESTION: 190

A project manager was just assigned to a project as the leader of an experienced agile team. How should the project manager influence the team to accomplish the project objectives?

- A. Assert judgment over the team.
- B. Increase the amount of subject matter experts (SMEs) to get better results.
- C. Express trust in the team's ability to fulfill the necessary deliverables.
- D. Use a plan-driven approach in order to demonstrate control over the project.

Answer: C ([LEAVE A REPLY](#))

NEW QUESTION: 191

In a project, one core team member tends to do all the work and ensures all tasks are completed. This core team member is soon leaving the project, which may make the project vulnerable. What should the project manager do?

- A. Assess a mechanism for knowledge transfer among the team members.
- B. Ensure the activities of this team member are distributed across the project team.
- C. Motivate the team member to stay by providing them with incentives.
- D. Ask human resources (HR) to counsel the team member to balance the workload.

Answer: A ([LEAVE A REPLY](#))

NEW QUESTION: 192

On November 1, \$1000 worth of work on task A was supposed to have been done (BCWS); however, the BCWP was \$850. Calculate the schedule variance:

- A. (\$150)
- B. \$100

- C. \$150
- D. (\$100)
- E. 85%

Answer: ([SHOW ANSWER](#))

NEW QUESTION: 193

Based on your success on previous projects, you have been asked to manage a project for a different department in your organization. This department has documented processes for most of their work. You realize that you will need to tailor many of their standard processes so that they will make sense for your new project. Which organizational process asset will probably help you the most?

- A. Project plan templates
- B. Project management information system (PMIS)
- C. Change management plan
- D. Infrastructure

Answer: A ([LEAVE A REPLY](#))

NEW QUESTION: 194

In Project Cost Management, which input is exclusive to the Determine Budget process?

- A. Resource calendars
- B. Organizational process assets
- C. Project schedule
- D. Scope baseline

Answer: A ([LEAVE A REPLY](#))

NEW QUESTION: 195

A project is progressing but stakeholders show little interest and supply minimal effort. To engage the stakeholders what should the project manager do first?

- A. Ensure that the communications management plan is being followed
- B. Ask management for assistance
- C. Document a risk detailing stakeholders' lack of involvement and the impact on the project.
- D. Encourage other managers to influence the stakeholders

Answer: A ([LEAVE A REPLY](#))

NEW QUESTION: 196

To account for uncertainty in a schedule, reserve analysis may be used. All the following are examples of contingency reserves EXCEPT _____

- A. Fixed number of work periods
- B. Percent of the estimated activity duration
- C. Buffers
- D. Productivity metrics

Answer: D (LEAVE A REPLY)

Section: Mix Questions

Explanation:

Duration estimates may include contingency reserves, and contingency should be identified clearly in schedule documentation. They are built into the overall project schedule to account for uncertainty. They also may be developed using quantitative analysis methods. When more information is known about the project, the contingency reserve may be used, reduced, or eliminated.

Valid PMP Dumps shared by TrainingQuiz.com for Helping Passing PMP Exam!

TrainingQuiz.com now offer the **newest PMP exam dumps**, the TrainingQuiz.com PMP exam **questions have been updated** and **answers have been corrected** get the **newest** TrainingQuiz.com PMP dumps with Test Engine here: <https://www.trainingquiz.com/PMP-practice-quiz.html> (2045 Q&As Dumps, **40%OFF Special Discount: Exam-Tests**)

NEW QUESTION: 197

You are currently the project manager at a rapidly growing retailer of high-performance audio equipment. You have been asked to lead the project to expand the retail business in the United States. You are currently deciding amongst three promising geographic locations: New York, Seattle, and San Francisco.

You have been asked that San Francisco has a smaller market potential, but the probabilities of success is high. On the other hand, the New York market has larger market potential, but the probability of success is low. Your project team member has given you the following forecast. Which of the following statements are true?

Exhibit:

	Probabilities	Year 1	Year 2	Year 3	NPV
San Francisco	0.7	100	200	300	\$481.59
	0.3	(100)	(100)	(100)	(\$248.89)
Seattle	0.5	250	300	500	\$650.86
	0.5	(100)	(100)	(100)	(\$248.89)
New York	0.3	200	400	600	\$963.19
	0.7	(100)	(100)	(100)	(\$248.89)

- A. You should select Seattle, as it provides the highest expected monetary value
- B. You should use multi-objective programming algorithms to determine which location to select
- C. You should select San Francisco, as it provides the highest expected monetary value
- D. You should select New York, as it provides the highest expected monetary value
- E. You should select San Francisco, as it provides the lowest NPV value

Answer: A (LEAVE A REPLY)

NEW QUESTION: 198

You are the project manager working on a research project for a new drug treatment. Your preliminary project schedule runs past the due date for a federal grant application. The manager

of the R&D department has agreed to release two resources to work on your project in order to meet the federal grant application date. This is an example of _____.

- A. adjusting the resource calendar
- B. fast tracking
- C. crashing
- D. resource leveling

Answer: C ([LEAVE A REPLY](#))

Crashing the schedule includes tasks such as adding resources to the critical path tasks or limiting project requirements.

NEW QUESTION: 199

The process of identifying and documenting relationships among the project activities is known as:

- A. Define Activities.
- B. Develop Schedule.
- C. Sequence Activities.
- D. Control Schedule.

Answer: ([SHOW ANSWER](#))

NEW QUESTION: 200

A project manager receives a serious complaint from a functional manager about a team member. What should the project manager do?

- A. Support the team member and provide documentation to the functional manager proving their performance.
- B. Replace the team member immediately to maintain a good relationship with the functional manager.
- C. Protect the team member and ask the project sponsor to minimize any external interruptions.
- D. Discuss the issue with the functional manager to understand the reason for the complaint.

Answer: D ([LEAVE A REPLY](#))

NEW QUESTION: 201

Which of the following schedule network analysis techniques is applied when a critical path method calculation has been completed and resources availability is critical?

- A. Resource planning
- B. Resource leveling
- C. Applying calendars
- D. Resource conflict management

Answer: ([SHOW ANSWER](#))

NEW QUESTION: 202

The most common form of organizational communication is

- A. Downward to subordinates
- B. Horizontal to customers
- C. Upward to management
- D. Horizontal to peers
- E. All of the other alternatives apply

Answer: ([SHOW ANSWER](#))

NEW QUESTION: 203

You are the project manager for Lucky Stars Candies. You've identified the deliverables and requirements and documented them where?

- A. In the project scope management document, which is used as an input to the Scope Definition process
- B. In the product requirements document, which is an output of the Scope Definition process
- C. In the project scope statement, which will be used as an input to the Create WBS process
- D. In the project specifications document, which is an output of the Scope Planning process

Answer: C ([LEAVE A REPLY](#))

The project scope statement contains an exhaustive list of the project deliverables, their requirements, and the measurable criteria used to determine project completion. The scope statement is an output of the Scope Definition process and is used as an input to the Create WBS process.

NEW QUESTION: 204

What is the definition of Direct and Manage Project Execution?

- A. Integrating all planned activities
- B. Developing and maintaining the plan
- C. Performing the activities included in the plan
- D. Execution of deliverables

Answer: C ([LEAVE A REPLY](#))

NEW QUESTION: 205

Which of the following is not a process of project human resource management?

- A. Information Distribution
- B. Organizational Planning
- C. Team Development
- D. Staff Acquisition

Answer: A ([LEAVE A REPLY](#))

NEW QUESTION: 206

A project manager finds an unexpected issue halfway through a customer's project. After analysis the project team determines that the issue will affect the timeline unless more resources are allocated to the project.

What should the project manager do?

- A. Meet with the project team to discuss internally whether they think cost is more important to the customer than the timeline
- B. Absorb the additional cost for the additional resources internally so that the project completes within the timeline
- C. Adjust the timeline since in the past the customer would not pay any additional costs then inform the customer of the change
- D. Inform the customer of the issue and discuss the options so that they are able to make a decision on cost versus timeline

Answer: D ([LEAVE A REPLY](#))

NEW QUESTION: 207

One of the stakeholders on the project led a change request a month back. He reached out to the project manager stating that he has not received any response yet. How can this situation be resolved?

- A. Reach out to your team leader to understand why it was missed
- B. By reviewing the issue log.
- C. By reviewing the integrated change control process.
- D. By reviewing the stakeholder register.

Answer: C ([LEAVE A REPLY](#))

NEW QUESTION: 208

A team is having a hard time completing work due to unclear requirements. They have not been able to complete an iteration successfully in several months.

In order to help the team, what should the project leader do?

- A. Recommend limiting the work in progress to improve the team's focus.
- B. Recommend that the product owner reviews the backlog refinement processes.
- C. Recommend a review of the team members' individual performances.
- D. Recommend that the team reviews the length of the iteration with the stakeholders.

Answer: ([SHOW ANSWER](#))

NEW QUESTION: 209

Which of the following is not a regulation?

- A. The building code for a city
- B. The documented way to dispose of old paint
- C. The average speed on a highway in a week
- D. The zoning for an industrial area

Answer: ([SHOW ANSWER](#))

Section: Mix Questions

NEW QUESTION: 210

A project team delivers a system in its pilot phase, and the customer identifies an issue that affects the end users. After the project team works on the issue for a week the customer informs the project manager's supervisor that the issue is not being addressed and requests immediate action.

What should the project manager do next?

- A. Review the communications management plan and take appropriate action
- B. Review the Perform Integrated Change Control process and take appropriate action
- C. view the project register and take appropriate action
- D. Review the quality management plan and take appropriate action

Answer: A ([LEAVE A REPLY](#))

NEW QUESTION: 211

In which phase is budgeting done?

- A. Monitoring & Controlling
- B. Executing
- C. Planning
- D. Initiating

Answer: C ([LEAVE A REPLY](#))

Section: Executing

Valid PMP Dumps shared by TrainingQuiz.com for Helping Passing PMP Exam!
TrainingQuiz.com now offer the **newest PMP exam dumps**, the TrainingQuiz.com PMP exam **questions have been updated** and **answers have been corrected** get the **newest** TrainingQuiz.com PMP dumps with Test Engine here: <https://www.trainingquiz.com/PMP-practice-quiz.html> (2045 Q&As Dumps, **40%OFF Special Discount: Exam-Tests**)

NEW QUESTION: 212

How many ADDITIONAL lines of communication will be created when the number of team members involved during the project increases from five to ten?

- A. 50
- B. 10
- C. 35
- D. 55
- E. 45

Answer: C ([LEAVE A REPLY](#))

NEW QUESTION: 213

Which Process Group includes the Manage Stakeholder Engagement process?

- A. Executing

- B. Planning
- C. Monitoring and Controlling
- D. Initiating

Answer: A (LEAVE A REPLY)

Reason: Control Stakeholder Engagement is in the Monitoring and Control Process.

NEW QUESTION: 214

You and your project team recognize the importance of project scope management to a project's overall success; therefore, you include only the work required for successful completion of the project. The first step in the Project Scope Management process is to_____

- A. Clearly distinguish between project scope and product scope
- B. Prepare a scope management plan
- C. Define and document your stakeholders' needs to meet the project's objectives
- D. Capture and manage both project and product requirements

Answer: B (LEAVE A REPLY)

Section: Mix Questions

Explanation:

The work involved in the six Project Scope Management processes begins by preparing a scope management plan, which is a subsidiary plan for the project management plan. It describes the Project Scope Management processes from definition to control.

NEW QUESTION: 215

During a project's execution phase, two key business stakeholders request additional requirements be made within the same timeframe. Due to limited project resources and budget, the project manager cannot fully meet the expectations of these stakeholders.

Which of the following techniques should the project manager adopt to obtain support from both of these key stakeholders?

- A. Smooth/accommodate
- B. Force/direct
- C. Withdraw/avoid
- D. Compromise/reconcile

Answer: (SHOW ANSWER)

Section: Executing

Explanation

NEW QUESTION: 216

Your company has asked you to be the project manager for the product introduction of its new DeskTop Rock media system. You recently published the project scope statement. Which of the following is not contained in the project scope statement?

- A. Requested changes
- B. Project configuration management requirements

- C. Constraints
- D. Project specifications

Answer: (SHOW ANSWER)

Requested changes are an output of the Scope Definition process. They are not part of the project scope statement.

NEW QUESTION: 217

Which of the following techniques uses a weighted average duration estimate to calculate activity durations?

- A. Simulations
- B. CPM
- C. PERT
- D. GERT

Answer: C (LEAVE A REPLY)

NEW QUESTION: 218

Which of the following choices indicates that a project has a burn rate of 1.2? Hint: Burn rate is the same as the Cost Performance Index

- A. The ACWP is 100 and the BCWP is 120.
- B. The BCWS is 100 and the BCWP is 120.
- C. The ACWP is 120 and the BCWP is 100.
- D. The BCWP is 100 and the BCWS is 120.

Answer: A (LEAVE A REPLY)

NEW QUESTION: 219

A project manager is leading a large project with an internal team as well as an external supplier. The project manager discovers through one of the stakeholders that the quality of the product provided by the external supplier does not meet the requirements.

What should the project manager do next?

- A. Start the change management process to adapt.
- B. Review the specifications in the underlying contract.
- C. Meet with the supplier to renegotiate the contract.
- D. Inform supplier management about possible penalties.

Answer: (SHOW ANSWER)

Section: Executing

NEW QUESTION: 220

At the end of a project, one of the suppliers is facing financial difficulties and is pushing the project manager to obtain financial, legal, and administrative approval in order to communicate formal project closure and ensure the transfer of liability. What should the project manager do next?

- A. Compare the achieved results to the contract requirements.
- B. Make the final payment as the project is completed.
- C. Escalate to higher management to expedite the approval.
- D. Transfer the remaining variances and close the project.

Answer: ([SHOW ANSWER](#))

NEW QUESTION: 221

The project manager notes that stakeholders are aware of the project and potential impacts and are actively engaged in ensuring that the project is a success. The engagement level of the stakeholders should be classified as:

- A. Leading
- B. Neutral
- C. Resistant
- D. Supportive

Answer: A ([LEAVE A REPLY](#))

NEW QUESTION: 222

The procurement department submits a request for proposal (RFP) to potential vendor to execute a project.

After the bidder conferences, the project manager receives an email from vendor A requesting clarification of the RFP.

What should the project manager do next.

- A. Email vendor A with the clarification
- B. Obtain management's approval before sending the information.
- C. Email all the vendors with the clarification
- D. the RFP with the clarification and resend it to all the vendors.

Answer: D ([LEAVE A REPLY](#))

NEW QUESTION: 223

Project cost control includes all of the following EXCEPT:

- A. Identifying various costing alternatives
- B. Bringing expected cost overruns within acceptable limits
- C. Informing stakeholders of approved changes
- D. Ensuring requested changes are agreed upon
- E. Monitoring cost performance to detect variances from cost baseline

Answer: A ([LEAVE A REPLY](#))

NEW QUESTION: 224

A project manager is managing a project that is operating in a remote, international location.

During the execution phase, a national event occurs. The project manager is concerned that the project may be negatively affected and has contacted the program manager who has agreed to

provide the resources to implement a contingency plan in the event that the project is negatively affected.

What management strategy is the project manager employing?

- A. Escalate
- B. Transfer
- C. Mitigate
- D. Accept

Answer: A (LEAVE A REPLY)

Section: Executing

Explanation

NEW QUESTION: 225

A project team has recently completed the initial sprint for developing an automated payroll system for a company. The project manager has scheduled a sprint planning meeting with the product owner and team members to discuss which features should be worked on next. Which two pieces of information does the project manager need in order to make this meeting productive and effective? (Choose two)

- A. Product backlog
- B. Burndown chart
- C. Company mission and vision
- D. Sprint goal
- E. Sprint charter

Answer: (SHOW ANSWER)

NEW QUESTION: 226

The organizational process assets that are of particular importance to Plan Communications are:

- A. Stakeholder positions and their influence
- B. Guidelines and knowledge bases
- C. Formal plans and procedures
- D. Lessons learned and historical information

Answer: (SHOW ANSWER)

Valid PMP Dumps shared by TrainingQuiz.com for Helping Passing PMP Exam!

TrainingQuiz.com now offer the **newest PMP exam dumps**, the TrainingQuiz.com PMP exam **questions have been updated** and **answers have been corrected** get the **newest** TrainingQuiz.com PMP dumps with Test Engine here: <https://www.trainingquiz.com/PMP-practice-quiz.html> (2045 Q&As Dumps, **40%OFF Special Discount: Exam-Tests**)

NEW QUESTION: 227

You are in the process project a project schedule for repainted your house, you first need to scrap off the existing paint, and then add a layer of primer. The primer provides the paint a better bonding surface so it sticks to the base material much better. Without priming, drywall surfaces will soak up more finish paint in some areas than in others, producing a splotchy effect. Unfortunately, you have to wait once the primer is applied you must wait until the primer dries before adding on the actual paint. You estimate that it will take 8 hours for the primary to dry. To correctly sequence these activities, which of the following should you do?

- A. Fast track the priming and painting tasks
- B. Add float time between the priming and painting tasks
- C. Add a lead time of 8 hours to the priming task
- D. Add a lag time 8 hours to the priming task

Answer: D ([LEAVE A REPLY](#))

NEW QUESTION: 228

A project is being executed The project's life cycle is defined as predictive however, a major deliverable will be handed over incrementally to the customer The assigned resources are experienced and reliable and are willing to make decisions that the project manager used to make after each incremental delivery on other projects What should the project manager do?

- A. Consult the product owner about letting the resources make decisions
- B. Schedule a steering committee meeting and obtain their approval on the request
- C. Inform the team that although this is a hybrid environment, the project manager must still be responsible for making decisions
- D. Support the decisions of the team and transfer the decision making responsibility to them.

Answer: A ([LEAVE A REPLY](#))

NEW QUESTION: 229

You've been hired as manager to design and construct a new casino in Las Vegas, over the next 18 months. Given the size of the project and the abbreviated time frame, you are attempting to identify ways to reduce the timeframes for many of various tasks. You've developed the WBS and created a Gantt chart using specialized scheduling software.

After analyzing the data, you've discovered several opportunities where tasks and phases may be overlapped in order to save time. This is an example of:

- A. Crashing and schedule
- B. Progressive elaboration
- C. Resource elaboration
- D. Fast tracking

Answer: ([SHOW ANSWER](#))

NEW QUESTION: 230

Qualitative risk analysis requires accurate data as its input. Risk data quality assessment ranking is a technique to evaluate the degree to which the data regarding risks would be useful. Risk quality data assessment involves examining all of the following EXCEPT:

- A. Time-criticality of risk related actions
- B. Quality of eh data
- C. Reliability and integrity of data
- D. Extent of understanding of risk

Answer: A ([LEAVE A REPLY](#))

NEW QUESTION: 231

A project manager develops a project's risk breakdown structure (RBS) divided into four categories. The team identifies a quality problem with one of the project deliverables. In what category should this risk be included?

- A. Organizational
- B. Technical
- C. Project management
- D. External

Answer: ([SHOW ANSWER](#))

NEW QUESTION: 232

A project manager is in rapid development mode on a joint application development module. The company wants delivery to occur in two weeks. The module needs to be integrated with other modules on a similar timeline, but release management has a three-week backlog. What should the project manager do?

- A. Speak to the team and slow the current pace to ensure the team is in alignment with the release date
- B. Have the team work toward the tighter deadline so that integration will be easier.
- C. Speak to the stakeholders to resolve the bottleneck and see how the entire process can be streamlined
- D. Push the team to deliver more so that the modules are developed and rolled out according to management's request

Answer: C ([LEAVE A REPLY](#))

NEW QUESTION: 233

The most appropriate project life cycle model for an environment with a high level of change and extensive stakeholder involvement in projects is:

- A. adaptive
- B. reflexive
- C. predictive
- D. iterative

Answer: A ([LEAVE A REPLY](#))

Section: Executing

NEW QUESTION: 234

The project charter was just approved and the project sponsor has given permission to proceed with the project. The program manager has confirmed that one of the requested key resources is also needed on another project at the same time. This will affect project delivery. What should the project manager do?

- A. Pay overtime to key resource to get the work done outside of working hours
- B. Talk to the program manager and about prioritizing this project over other projects so the key resources are available
- C. Have a meeting with project manager of the other project to find a resource optimization solution that works for both projects
- D. Speak with the client to see if the project delivery deadline can be delayed due to resource availability

Answer: (SHOW ANSWER)

NEW QUESTION: 235

After preparing the final project report, the project manager realizes that the stakeholder distribution list is incomplete. What should the project manager do?

- A. Refer to the stakeholder list created during the development of the project charter.
- B. Refer to the communications management plan.
- C. Gather inputs from the team to develop the list of stakeholders.
- D. Ask the project sponsors for a list of stakeholders.

Answer: B (LEAVE A REPLY)

Section: Closing

Explanation/Reference:

NEW QUESTION: 236

A project manager is using a hybrid approach for a project. The project team created and reviewed the risk log with the stakeholders at the beginning of the project. However, midway through the project, the project team and stakeholders became misaligned with the risks and mitigation strategies. When should the risks be reviewed to ensure alignment between the project team and the stakeholders'?

- A. During the retrospectives
- B. During each steering committee meeting
- C. During each iteration and review
- D. During the risk register update

Answer: (SHOW ANSWER)

NEW QUESTION: 237

Qualitative risk analysis requires accurate data as its input. Risk data quality assessment ranking is a technique to evaluate the degree to which the data regarding risks would be careful. Risk quality data assessment involves examining all of the following EXCEPT:

- A. Reliability and integrity of data
- B. Probability of the risks
- C. Data available about the risk
- D. Quality of eh data
- E. Extent of understanding of risk

Answer: B (LEAVE A REPLY)

NEW QUESTION: 238

You are the project manager. Which of the following would be required to ascertain what impact a change would have on the project in a situation where a customer requests a scope change in the project? Note: you already have the work breakdown structure, change request and scope management plan.

- A. A Pareto diagram
- B. A responsibility matrix.
- C. A histogram
- D. A Monte Carlo simulation.
- E. Performance reports.

Answer: E (LEAVE A REPLY)

NEW QUESTION: 239

Which process in Project Time Management includes reserve analysis as a tool or technique?

- A. Estimate Activity Resources
- B. Sequence Activities
- C. Estimate Activity Durations
- D. Develop Schedule

Answer: C (LEAVE A REPLY)

Section: Monitoring and Controlling

Explanation/Reference:

NEW QUESTION: 240

Your company policy allows accepting gifts from customer within certain limit.

Your customer is giving you a gift which is beyond limit of your company policy.

You have given a gift to the customer's representative already with of similar value.

What should you do?

- A. Contact your company's senior management and ask for assistance.
- B. Ask your customer to about company policy.
- C. Accept it and don't tell to any one.
- D. Refuse it.

Answer: (SHOW ANSWER)

Best option is Contact your company's senior management and ask for assistance.

NEW QUESTION: 241

Your company has been awarded a contract for project management consulting services for a major government agency. You were a member of the proposal writing team, are PMP certified, and you are the project manager. You are now working to prepare your project management plan, which is to be submitted in one week. You decided to use some facilitation techniques to help develop your plan. While a number are possible, you selected_____

- A. Conflict resolution
- B. Checklist analysis
- C. SWOT analysis
- D. Assumptions analysis

Answer: A (LEAVE A REPLY)

Explanation/Reference:

Explanation:

Facilitation techniques are a tool and technique in develop project management plan process. Other examples are brainstorming, problem solving, and meeting management. They are used to help teams and individuals achieve agreement to accomplish the project's objectives.

Valid PMP Dumps shared by TrainingQuiz.com for Helping Passing PMP Exam!

TrainingQuiz.com now offer the **newest PMP exam dumps**, the TrainingQuiz.com PMP exam **questions have been updated** and **answers have been corrected** get the **newest** TrainingQuiz.com PMP dumps with Test Engine here: <https://www.trainingquiz.com/PMP-practice-quiz.html> (2045 Q&As Dumps, **40%OFF Special Discount: Exam-Tests**)

NEW QUESTION: 242

A project manager is developing a project risk register. What tool or technique should the project manager use to generate a list of all possible project risks?

- A. Monte Carlo simulation
- B. Tornado diagram
- C. Brainstorming
- D. Sensitivity analysis

Answer: C (LEAVE A REPLY)

Section: Planning

Explanation

NEW QUESTION: 243

A new project requires resources with specific skills and competencies from various company departments.

Since most company staff are already assigned to other projects, the project manager must identify and agree on available internal human resources, and hire external experts.

What should the project manager use first to obtain resources?

- A. Negotiation skills
- B. Acquisition skills
- C. Individual and team assessment tools
- D. Requirements analysis tools

Answer: B ([LEAVE A REPLY](#))

Section: Initiation

Explanation

NEW QUESTION: 244

Which tool is used to develop technical details within the project management plan?

- A. Expert judgment
- B. Project management methodology
- C. Project management information system (PMIS)
- D. Project selection methods

Answer: A ([LEAVE A REPLY](#))

Section: Planning

NEW QUESTION: 245

A product owner has provided the team with a prioritized backlog for the initial launch of a new product. After analysis, the team concludes that some work is missing to support the initial launch and provides this information to the product owner. The product owner acknowledges the missing work and adds it to the bottom of the backlog. The team is not happy with the prioritization that the missing work received.

What should the project manager do in this situation?

- A. Analyze and reprioritize the backlog and provide the decision to the product owner and team.
- B. Empower the product owner by supporting the decision and instructing the team to follow the prioritization as provided.
- C. Let the project team pull the recommended work from the bottom of the backlog to maximize value creation.
- D. Recommend the product owner prioritize the missing work higher because it is needed for the minimum viable product (MVP).

Answer: D ([LEAVE A REPLY](#))

NEW QUESTION: 246

During what process is the quality policy determined?

- A. Planning

- B. Initiating
- C. Controlling
- D. Executing

Answer: A ([LEAVE A REPLY](#))

NEW QUESTION: 247

In a multi-site development project, sharing documents within the project team is identified as a security risk.

Introducing a new software release would mitigate this risk.

What should the project manager do first?

- A. Update the project management plan.
- B. Assess the impact on the project.
- C. Perform a Monte Carlo simulation.
- D. Review the assumptions log.

Answer: ([SHOW ANSWER](#))

Section: Executing

NEW QUESTION: 248

You are working on a new project in your organization. You need to decide how best to staff the project and handle all its resource requirements. Your first step should be to _____

- A. Conduct a make-or-buy analysis
- B. Conduct a market survey
- C. Solicit proposals from sellers using an RFP to determine whether you should outsource the project
- D. Review your procurement department's qualified-seller lists and send an RFP to selected sellers

Answer: ([SHOW ANSWER](#))

Section: Mix Questions

Explanation:

A make-or-buy analysis is a plan procurement management tool and technique used to determine whether a particular product, service, or result can be produced or performed cost effectively by the performing organization or should be contracted out to another organization. The analysis includes both direct and indirect costs and any administrative costs incurred to manage the contractor.

NEW QUESTION: 249

A project's earned value (EV) report indicates that an activity's cost variance (CV) is 5,000 and its schedule variance (SV) is 1,000. What is the status of this activity?

- A. Behind schedule and over budget
- B. On schedule and within budget
- C. Behind schedule and within budget

D. Ahead of schedule and over budget

Answer: D ([LEAVE A REPLY](#))

NEW QUESTION: 250

Which is not part of the purchasing cycle?

A. Defined need and prepare and issue purchase order.

B. Prepare and issue purchase order

C. Inspection

D. Defined need

E. Transmit need

Answer: C ([LEAVE A REPLY](#))

NEW QUESTION: 251

Which tool and technique integrates scope, cost and schedule in measuring project performance?

A. Earned value

B. Trend analysis

C. Variance analysis

D. Performance report

Answer: A ([LEAVE A REPLY](#))

NEW QUESTION: 252

A project manager is part of a team that is launching a series of features to comply with a new regulation. The team has only 6 weeks to release the features to the legacy applications. During the standup meeting, a software engineer indicated that the development of an important feature is on hold until the assigned designer completes a specific task. This delay is a serious road block to meeting the release date.

What should the project manager do?

A. Contact the design team manager and ask to reconsider the priority list based on the latest situation,

B. Meet with the design team manager to inform them of the current status and request an additional designer.

C. Ask the software engineer to move forward without completing the important feature.

D. Meet with the designer to share the current status and develop a solution to complete the task.

Answer: A ([LEAVE A REPLY](#))

NEW QUESTION: 253

Working on your project management training curricula project, you decided it would be beneficial to you to become an active member of the Project Management Institute as part of the objectives of your project is to ensure it is aligned with PMI's best practices. To complement PMI's Work Breakdown Structure Practice Standard, you learned PMI was requesting volunteers to

participate in development of a similar standard on the Scope Statement. You volunteered, and now the Standard is issued. This is an example of:

- A. Improving your own competency as a project manager
- B. Corrective action
- C. Preventive action
- D. A requirement for you to immediately update your project management plan

Answer: B (LEAVE A REPLY)

Section: Mix Questions

Explanation:

When you volunteered, you signed a confidentiality statement so you could not disclose what was under way on this activity. Now the Standard has been issued, and to stay in alignment with PMI's best practices, you need to issue a change request based on corrective action to realign the performance of the work of your project with your project management plan.

NEW QUESTION: 254

You are the project manager within an information technology department of a large retailer. In order to allow for better real-tracking, in inventory control, and supply chain management, your company is financing a project to install and to install and deploy RFID on all items of merchandise. As the project manager, you've just completed the select sellers' process, and selected 5 different vendors on your qualified sellers list who has responded to your company's RFP. One of the vendors remaining the qualified sellers list is RFID-PM Inc. although you have no financial interest in this company, one of your old high school buddies, Terence, sits on the board of directors of this company. Is there a conflict of interest in this situation?

- A. Because of your friendship with Terence, a conflict of interest exist that must be disclosed immediately
- B. Since neither you nor your family members has any financial interests in this company there is no conflict of interest
- C. In order to protect your privacy, you only have to disclose your relationship with RFIDPM, Inc. if you are directly questioned
- D. Depending on the depth of your friendship with Terence, a conflict of interest could exist

Answer: B (LEAVE A REPLY)

NEW QUESTION: 255

A Work Breakdown Structure:

- A. All of the other alternatives apply.
- B. both 1) assures all work is identified and 2) subdivides the project into manageable segments
- C. subdivides the project into manageable segments
- D. assures all work is identified
- E. provides the project sponsor with a time-phase task summary

Answer: B (LEAVE A REPLY)

NEW QUESTION: 256

A resource pool description provides:

- A. What are the resources are available, at what times and in what patterns
- B. Duration of the project
- C. Performance of the pool resources
- D. The unit cost for each resource

Answer: A (LEAVE A REPLY)

A resource pool description: What are the resources are available, at what times and in what patterns

Valid PMP Dumps shared by TrainingQuiz.com for Helping Passing PMP Exam!

TrainingQuiz.com now offer the **newest PMP exam dumps**, the TrainingQuiz.com PMP exam **questions have been updated** and **answers have been corrected** get the **newest** TrainingQuiz.com PMP dumps with Test Engine here: <https://www.trainingquiz.com/PMP-practice-quiz.html> (2045 Q&As Dumps, **40%OFF Special Discount: Exam-Tests**)

NEW QUESTION: 257

During the execution of a project with a limited budget, some of the team members suggest saving money by skipping quality management. What should the project manager do?

- A. Ask the sponsor to increase the budget.
- B. Ask the stakeholder to change the quality standards.
- C. Accept the team's suggestion due to the limited budget.
- D. Educate the team on the importance of quality management.

Answer: D (LEAVE A REPLY)

Section: Executing

NEW QUESTION: 258

A project's original budget at completion (BAC) was calculated as US\$100,000, but the estimate at completion (EAC) is US\$120,000 if the schedule performance index (SPI) is equal to 1, what is the cost performance index (CPI)?

- A. Equal to 1.2
- B. Greater than 1
- C. Equal to 1
- D. Less than 1

Answer: A (LEAVE A REPLY)

NEW QUESTION: 259

Your goal as a project manager is to manage stakeholders to the best of your ability. However, if there are conflicts among stakeholders, they should usually be resolved in favor of:

- A. Team Members
- B. Business Partner/Project Sponsor
- C. All Stakeholders
- D. Customer

Answer: D ([LEAVE A REPLY](#))

NEW QUESTION: 260

Which of the following consists of the detailed project scope statement and its associated WBS and WBS dictionary?

- A. Scope plan
- B. Scope baseline
- C. Product scope
- D. Scope management plan

Answer: B ([LEAVE A REPLY](#))

NEW QUESTION: 261

Enterprise Environmental Factors includes some elements such as:

- A. Organizational Structure, Culture, and infrastructure
- B. Project files from previous projects (e.g., scope, cost, schedule and performance measurement baselines)
- C. Project plan templates
- D. Project closure guidelines or requirements

Answer: A ([LEAVE A REPLY](#))

NEW QUESTION: 262

All the following elements are organizational process asset updates, resulting from closing a project or phase EXCEPT _____

- A. Project files
- B. Project or phase closure documents
- C. Historical information
- D. Final product, service, or result transition

Answer: D ([LEAVE A REPLY](#))

Explanation/Reference:

Explanation:

All the elements are outputs of the close project or phase processes, but the final product, service, or result transition is not part of the organizational process assets. It is an output on its own and involves the product that the project was created to produce.

NEW QUESTION: 263

Which of the following is CORRECT about quality improvements?

- A. They occur only through experience of the project manager, team, and sponsor.
- B. They are a tool of Perform Quality Assurance and an output of Verify Scope.
- C. They are a product of cooperation between the customer and the project manager.
- D. They require the preparation of change requests or the recommendation of corrective actions.

Answer: D ([LEAVE A REPLY](#))

NEW QUESTION: 264

In a typical project, project managers spend most of their time:

- A. Communicating
- B. Estimating
- C. Controlling
- D. Scheduling

Answer: A ([LEAVE A REPLY](#))

NEW QUESTION: 265

Which of the following is an output of the Monitor and Control Project Work process?

- A. Project management plan
- B. Performance reports
- C. Organizational process assets
- D. Change requests

Answer: ([SHOW ANSWER](#))

NEW QUESTION: 266

Which illustrates the connection between work that needs to be done and its project team members?

- A. Work breakdown structure (WBS)
- B. Staffing management plan
- C. Network diagrams
- D. Responsibility assignment matrix (RAM)

Answer: ([SHOW ANSWER](#))

NEW QUESTION: 267

Which of the following statements are FALSE regarding project time management?

- A. Activity resource estimating involves estimating type and quantities of resources required to perform each schedule activity
- B. Schedule cost involving changes to the project schedule
- C. Schedule development involves analyzing activity sequences, durations, resource requirements in order to create project schedule
- D. None of the choices are correct
- E. Activity sequencing involves identifying dependencies among schedule activities

Answer: D ([LEAVE A REPLY](#))

NEW QUESTION: 268

In order for a matrix organizational approach to be successful, the two-boss situation should be resolved.

To overcome the two-boss problem, it is important to_____

- A. Have the project manager and the functional manager work together to complete performance evaluations
- B. Prepare a responsibility chart to define responsibilities
- C. Guarantee a balance of power between the functional manager and the project manager
- D. Promote interface relationship management

Answer: ([SHOW ANSWER](#))

Section: Mix Questions

Explanation:

In a matrix environment, project team members have two bosses: the project manager and their functional line manager. People often are unclear as to which manager is their "real" boss, as there may be a continual shifting balance of power. To avoid confusion regarding performance issues, it is a best practice to have the project manager and functional line manager complete the individual's performance evaluations. Also, greater weight should be given to the project manager's assessment for the time the individual actually worked on the project.

NEW QUESTION: 269

Risks that may affect the project can be identified and organized into risk categories. Which of the following is a not possible risk category?

- A. Environmental
- B. Organizational
- C. None of the choices are correct
- D. Technical
- E. External

Answer: C ([LEAVE A REPLY](#))

NEW QUESTION: 270

The purpose of the Taguchi method is to_____

- A. Manage the flow of material for better visibility and control
- B. Use statistical techniques to compute a "loss function" to determine the cost of producing products that fail to achieve a target value
- C. Design, group, and manage production operations as self-contained flexible cells capable of start-to-finish processing of a family of items
- D. Regulate coordination and communication among process stages

Answer: B ([LEAVE A REPLY](#))

Section: Mix Questions

Explanation:

The Taguchi method is used to estimate the loss associated with controlling or failing to control process variability. It is based on the principle that by carefully selecting design parameters to produce robust designs, an organization can produce products that are more forgiving and tolerant. The tool helps determine the value or break-even point of improving a process to reduce variability.

NEW QUESTION: 271

A company attorney, newly hired by the company, walks into the project manager's office and tells her that he is ready to work with her on the procurement process. The project manager has little experience with procurement, so she is excited to have the assistance. With which of the following would it be BEST for the project manager to ask the attorney for help?

- A. Contract change control system, payments, and change requests
- B. Claims administration, audit results, and updating organizational process assets
- C. Recommended corrective actions, performance reporting, and records management system
- D. Procurement documentation, project management plan updates, and procurement management plan updates

Answer: ([SHOW ANSWER](#))

Valid PMP Dumps shared by TrainingQuiz.com for Helping Passing PMP Exam!

TrainingQuiz.com now offer the **newest PMP exam dumps**, the TrainingQuiz.com PMP exam **questions have been updated** and **answers have been corrected** get the **newest** TrainingQuiz.com PMP dumps with Test Engine here: <https://www.trainingquiz.com/PMP-practice-quiz.html> (2045 Q&As Dumps, **40%OFF Special Discount: Exam-Tests**)

NEW QUESTION: 272

The estimated cost of completing all the activities considered in a schedule will be US\$14,500. The project's sponsor requires a level of certainty about the cost baseline of at least 90%. As a result of a Monte Carlo simulation, the projected cost calculated is:

Probability	Estimated Cost
40%	US\$10,000
50%	US\$12,000
60%	US\$13,000
70%	US\$15,000
80%	US\$18,000
90%	US\$20,000
100%	US\$21,000

What should the contingency reserve be in order to fulfill the sponsor's requirement?

- A. US\$5,500
- B. US\$6,500
- C. US\$7,000
- D. US\$8,200

Answer: ([SHOW ANSWER](#))

Section: Planning

NEW QUESTION: 273

Using Force field analysis to monitor and control how attributes of a project manager and the team influence a project, which should not be found among the strongest driving forces for personal drive, leadership and motivation?

- A. Work challenge
- B. First project management experience
- C. Desire for accomplishment
- D. Interest in project

Answer: B ([LEAVE A REPLY](#))

NEW QUESTION: 274

During an ongoing project a key resource asks the project manager about the project purpose and if it is aligned with the organization's strategy What should the project manager share with the key resource?

- A. The updated project management plan
- B. The updated scope management plan
- C. The updated communications management plan
- D. The updated benefits management plan

Answer: ([SHOW ANSWER](#))

NEW QUESTION: 275

Project Risk Management is based on which of the following premises:

- A. we cannot control risk events.
- B. All of the other alternatives apply.
- C. project risk impact can be measured and controlled
- D. the future is unknown.
- E. unknowns can result in risks or opportunities.

Answer: ([SHOW ANSWER](#))

NEW QUESTION: 276

One of your friends is a manager at telecommunications company. She is currently managing a project developing a VoIP (Voice over IP) gateway that addresses the challenges facing service providers deploying packet-based voice networks. The gateway offers a comprehensive approach to implementing high-density carrier-class voice over packet gateway applications. All

the technical work has already been completed on the project, and the project is in the closing phase. Which of the following should be performed at this stage?

- A. Ensure that the project is integrated with other projects
- B. Documents lessons learned
- C. Perform scope verification
- D. Verify the quality of process

Answer: ([SHOW ANSWER](#))

NEW QUESTION: 277

Which of the following is not a scope management process?

- A. Scope planning
- B. Scope verification
- C. Scope Definition
- D. Initiation
- E. Scope change control

Answer: E ([LEAVE A REPLY](#))

NEW QUESTION: 278

Because critical distribution needs were not identified and considered, an upcoming product is cancelled one day before the announced launch. What should have been better developed to prevent this?

- A. Stakeholder engagement plan
- B. Scope management plan
- C. Risk management plan
- D. Communications management plan

Answer: C ([LEAVE A REPLY](#))

Section: Planning

NEW QUESTION: 279

Which of the following conflict resolution techniques describes a loselose situation where one of the parties involved in the conflict reduces to discuss the conflict, and hence, a resolution is never achieved

- A. Withdrawal
- B. Compromise
- C. Forcing
- D. Confrontation
- E. Smoothing

Answer: A ([LEAVE A REPLY](#))

NEW QUESTION: 280

Halfway through project execution, stakeholders ask for equipment that was expected to be procured. The project manager explains that the equipment was purchased, but differs from what the stakeholders are currently asking for. This is because the initial requirements were changed during a previous meeting.

What should the project manager have done to avoid this situation?

- A. Ensured changing stakeholder needs and requests were properly monitored
- B. Ensured project requirements were validated and communicated with the procurement team
- C. Ensured that communications were sent to all stakeholders when requirements change
- D. Ensured procurement contracts were able to be canceled when situations like this arise

Answer: C ([LEAVE A REPLY](#))

NEW QUESTION: 281

Projects frequently do not meet customer expectations from which of the following reasons?

- A. Poor risk management by the contractor running the project
- B. Poor technical ability of the contractor running the project for the customer
- C. Technical inability and poor risk management by the contractor
- D. Unclear Scope definition by the customer for whom the project is performed

Answer: C ([LEAVE A REPLY](#))

NEW QUESTION: 282

A project team member is struggling to understand a specific requirement. How should a servant leader address this issue?

- A. Assist by connecting the product owner with the team member to discuss what problem is to be solved
- B. Deprioritize the requirement and assign a task for it to be restated to provide the necessary clarity
- C. Assess and evaluate the team member's skills to ensure alignment to the particular requirement and solution
- D. Reassign the requirement to another team member who may have ideas on how to meet the requirement

Answer: B ([LEAVE A REPLY](#))

NEW QUESTION: 283

All the following are examples of project document updates from the manage project team process EXCEPT _____

- A. Issue log
- B. Roles description
- C. Project staff assignments
- D. Personnel skills

Answer: ([SHOW ANSWER](#))

Section: Mix Questions

Explanation:

Personnel skill updates are an example of an enterprise environmental factor that may require updates as a result of the manage project team process along with inputs to the organizational performance appraisals.

NEW QUESTION: 284

All of the following are true of Administrative Closure except:

- A. It includes verifying and documenting project results
- B. It should be delayed until project completion
- C. It includes collection of project records
- D. It includes analysis of project success and effectiveness

Answer: B (LEAVE A REPLY)

NEW QUESTION: 285

One of the project manager's important assignments is to formally revise project compliance as it pertains to user data protection regulations. What should the project manager do to monitor compliance?

- A. Assess the risk register.
- B. Complete sprint reviews
- C. Conduct project reviews.
- D. Perform retrospectives.

Answer: D (LEAVE A REPLY)

NEW QUESTION: 286

An issue requires the execution of the project's contingency plan, which impacts the schedule. What should the project manager do?

- A. Initiate a risk audit.
- B. Issue a change request.
- C. Review the cost impact.
- D. Update the contingency plan.

Answer: (SHOW ANSWER)

Section: Executing

Valid PMP Dumps shared by TrainingQuiz.com for Helping Passing PMP Exam!

TrainingQuiz.com now offer the **newest PMP exam dumps**, the TrainingQuiz.com PMP exam **questions have been updated** and **answers have been corrected** get the **newest**

TrainingQuiz.com PMP dumps with Test Engine here: <https://www.trainingquiz.com/PMP-practice-quiz.html> (2045 Q&As Dumps, **40%OFF** Special Discount: **Exam-Tests**)

NEW QUESTION: 287

The terms strong matrix, balanced matrix, and weak matrix when applied to the matrix structure in project organization refer to the_____

- A. Ability of the organization to achieve its goals
- B. Physical proximity of project team members to one another and to the project manager
- C. Degree of the project manager's authority
- D. Degree to which team members bond together

Answer: C (LEAVE A REPLY)

Explanation/Reference:

Explanation:

In a strong matrix organization, the balance of power shifts toward the project manager. In a weak matrix organization, the balance of power shifts toward the functional or line manager.

NEW QUESTION: 288

The primary communication skills you will use in working with functional managers will be:

- A. Problem solving
- B. Public relations
- C. Team building
- D. Negotiating

Answer: D (LEAVE A REPLY)

NEW QUESTION: 289

for a project has reported the potential for a delivery delay due to a technical issue with the sub-supplier To stay on schedule, the vendor proposed replacing the sub- supplier's component with a similar part that is different from the one that is stipulated in the project specifications.

What should the project manager do next?

- A. Instruct the vendor to use the part that is compliant with the project specifications and update the schedule
- B. Accept the proposed replacement in order to keep procurement activities on track
- C. Consult with a subject matter expert (SME) to see if the proposed change is acceptable
- D. Insist on using the component per the project specifications and air freight the equipment to mitigate the delay

Answer: C (LEAVE A REPLY)

NEW QUESTION: 290

According to the 80/20 rule, 80 percent of the problems are because of 20 percent of the causes. To facilitate finding out which are the most probable defects, you do a rank ordering of the defects using:

- A. Inspection
- B. Statistical Sampling
- C. Control Chart

D. Pareto Diagrams

Answer: D ([LEAVE A REPLY](#))

NEW QUESTION: 291

Your organization is adopting a project-based approach to business, which has been difficult. Although project teams have been created, they are little more than a collection of functional and technical experts who focus on their specialties. You are managing the company's most important project. As you begin this project, you must place a high priority on_____

- A. Creating an effective team
- B. Identifying the resources needed to finish the project on time
- C. The best way to communicate status to the CEO
- D. Establishing firm project requirements

Answer: A ([LEAVE A REPLY](#))

Section: Mix Questions

Explanation:

An effective team is critical to project success, but such a team is not born spontaneously. In early project phases, it is vitally important for the project manager to place a high priority on initiating and implementing the team-building process.

NEW QUESTION: 292

During the lessons learned workshop, one stakeholder mentioned that the project was unsuccessful as it did not deliver the expected business value. What should the project manager do to address this concern?

- A. Review the business benefits realization plan with the stakeholders.
- B. Review the project management plan budget with the stakeholders.
- C. Review the communications management plan with the stakeholders,
- D. Review the project management plan tasks with the stakeholders.

Answer: A ([LEAVE A REPLY](#))

NEW QUESTION: 293

A project has been ongoing for a year. Early in the year, its schedule performance index (SPI) was 1.2; its most recent SPI is 0.7.

What did the project manager use to track and communicate this information?

- A. Project communications
- B. Project management information system (PMIS)
- C. Performance reporting
- D. Variance analysis

Answer: D ([LEAVE A REPLY](#))

Section: Executing

NEW QUESTION: 294

Just as a team reaches a mutual consensus on a preferred design, a stakeholder submits a request to add new features that enhance the company's competitive advantage. What should the project manager do?

- A. Reject all requested changes and bypass the company's change control process.
- B. Encourage the project team to add premium features to impress the client.
- C. Start the process to include the new features of the product on the next iteration.
- D. Allow all requested changes and bypass the company's change control process.

Answer: A ([LEAVE A REPLY](#))

NEW QUESTION: 295

In the planning phase, a project manager receives identified risks from the sponsors and subject matter experts (SMEs) and wants to develop a risk response strategy for them.

What should the project manager do first?

- A. Assign allocated budget to cover key risks.
- B. Perform a risk reserve analysis.
- C. Agree on the criteria to prioritize risks.
- D. Assign a risk responsibility to each team member.

Answer: C ([LEAVE A REPLY](#))

NEW QUESTION: 296

A project manager is working on a global project with local stakeholders in each region. When developing the resource management plan, how should the project manager structure the teams?

- A. Virtually
- B. By collocating the team
- C. By functional group
- D. Asynchronously

Answer: A ([LEAVE A REPLY](#))

NEW QUESTION: 297

A new project manager was assigned to a project during implementation. The project manager realized that new tax policies are creating a risk for a cost overrun by 25%. The project manager updated the risk register and kept the project running as normal. The CEO has announced that the project could be cancelled since the acceptable cost overrun is only 20%. The project manager was quite surprised as this was new information.

What should the project manager have done to avoid this?

- A. Implemented the stakeholder engagement plan correctly.
- B. Provided a proper risk response
- C. Ensured the risk tolerance of the company was properly updated
- D. Implemented the communications management plan properly

Answer: D ([LEAVE A REPLY](#))

NEW QUESTION: 298

Sensitivity analysis helps to determine which risks might have the greatest impacts on the project and will require a carefully crafted risk assessment. Your project team has identified several potential risks on your current project that could have a significant impact if they occurred. The team examined the impact of the risks by keeping all of the uncertain elements at their baseline values. Which of the following will the team use to display this information?

- A. Control Chart
- B. Tornado Diagram
- C. SWOT (Strength, Weakness, Opportunities, and Threat)
- D. Monte Carlo Simulation

Answer: B ([LEAVE A REPLY](#))

NEW QUESTION: 299

You are the Project Manager on a cellular bluetooth amplifier project and are in the Planning phase. During a team meeting, a Functional Manager attempts to validate if the project meets company goals. The Functional Manager will report this finding back to senior management to determine if the project should continue, be modified or be canceled. What is this process called?

- A. Delphi Technique
- B. Management by objectives (MBO).
- C. Return on investment
- D. Management product analysis

Answer: B ([LEAVE A REPLY](#))

NEW QUESTION: 300

A technical requirement has which of the following characteristics:

- A. typically describe physical dimensions and performance requirements
- B. developed in cooperation with the user
- C. written in non-technical language
- D. a communication tool between the user and the design team
- E. easy to understand

Answer: ([SHOW ANSWER](#)**)**

NEW QUESTION: 301

After a project status meeting, the project manager realizes that the project is under budget, quality checks are positive, and the schedule variance is negative. How should the project manager qualify the project status?

- A. On schedule
- B. Stopped
- C. Behind schedule
- D. Ahead of schedule

Answer: C ([LEAVE A REPLY](#))

Valid PMP Dumps shared by TrainingQuiz.com for Helping Passing PMP Exam!

TrainingQuiz.com now offer the **newest PMP exam dumps**, the TrainingQuiz.com PMP exam **questions have been updated** and **answers have been corrected** get the **newest** TrainingQuiz.com PMP dumps with Test Engine here: <https://www.trainingquiz.com/PMP-practice-quiz.html> (2045 Q&As Dumps, **40%OFF** Special Discount: **Exam-Tests**)

NEW QUESTION: 302

A project team is reviewing the control chart to confirm that deliverables are within control limits. To guarantee report delivery timeliness, what should the project manager focus on managing?

- A. Time
- B. Communication
- C. Schedule
- D. Quality

Answer: ([SHOW ANSWER](#))

NEW QUESTION: 303

A strike at a contracted production plant affects the delivery of a project's major deliverable and impacts project objectives. To what should the project manager refer to address this issue?

- A. Standardized bid documents
- B. Managing multiple suppliers documents
- C. Procurement statement of work (SOW)
- D. Risk response plan

Answer: D ([LEAVE A REPLY](#))

Section: Executing

NEW QUESTION: 304

When sequencing activities, what does the common acronym FF stand for?

- A. Fixed Fee
- B. Fixed Finish
- C. Free Float
- D. Finish-to-Finish

Answer: D ([LEAVE A REPLY](#))

NEW QUESTION: 305

One of your project team members has made a technological breakthrough on an R & D project. The result will be new business for the company, as well as a company patent. The team member received a company bonus. The motivational strategy used here is:

- A. Linking pay and performance

- B. Freedom in the work place
- C. Job enrichment
- D. Behavior modification
- E. All of the other alternatives apply

Answer: A ([LEAVE A REPLY](#))

NEW QUESTION: 306

Some members of a project team work from home. During a weekly video-conference. much time is lost due to disconnected or dropped participants, background noise, strong interference, or multiple people speaking simultaneously. People are becoming annoyed and ask not to participate.

What should the project manager do?

- A. Define and train the team on a set of minimum requirements, rules for home and remote offices, and meeting etiquette.
- B. Change the frequency of the weekly meetings to monthly.
- C. Request that all the team members meet physically for the weekly meeting.
- D. Hold individual meetings with team members and consolidate the information in meeting minutes for distribution.

Answer: A ([LEAVE A REPLY](#))

NEW QUESTION: 307

Which of the following statement about Project Planning Methodology is not accurate?

- A. Project planning methodology may require soft tools like facilitated startup meetings
- B. The project planning methodology may include standard forms and templates, or simulations.
- C. Project Planning methodology includes tools and techniques to gather, integrate and disseminate the outputs of project management process
- D. Project planning methodology may require hard tools like Project Management software

Answer: C ([LEAVE A REPLY](#))

NEW QUESTION: 308

Some of the more experienced members of a project team have complained about the project manager. The senior project team members feel that the project manager is micromanaging them and preventing them from completing their work.

What should the project manager do when made aware of these issues?

- A. Adjust the project manager's management style to better fit senior team members.
- B. Set up a team building event to bring synergy back to the project team.
- C. Ask for advice on how to be a better mentor to these team members.
- D. Meet daily with each senior team member to monitor project status

Answer: B ([LEAVE A REPLY](#))

NEW QUESTION: 309

All of the following statements describe the activity list except which one?

- A. The activity list includes all activities of the project.
- B. The activity list is an extension of and a component of the WBS.
- C. The activity list is an output of the Activity Definition process.
- D. The activity list includes an identifier and description of the activity.

Answer: B (LEAVE A REPLY)

The activity list is a component of the project schedule, not the WBS. The activity list includes all the project activities, an identifier, and a description of the activity. The activity list is an out-put of the Activity Definition process.

NEW QUESTION: 310

An agile project is running its fifth iteration out of eight After the last iteration planning the team was informed that there is a new competitor in the market and it is necessary to move faster to ensure market share is not missed What should the project manager do?

- A. Ask the team to increase the velocity to launch the product as soon as possible
- B. Ask the sponsor to add more people to the team
- C. Add the competitor's functionalities to the product backlog to improve the product
- D. Help the team to find a new approach to launch the product as soon as possible

Answer: D (LEAVE A REPLY)

NEW QUESTION: 311

While performing an earned value analysis (EVA), a project manager notices that the cost performance index (CPI) is not what was expected.

The project manager investigates and is unable to locate purchase orders or receipts for items used in the project.

What should have been used to prevent this from occurring?

- A. Audits
- B. Inspections
- C. Data analysis
- D. Risk management

Answer: A (LEAVE A REPLY)

Section: Planning

NEW QUESTION: 312

After completion of a project with specific users in various countries, the project manager's supervisor asks if the project users are satisfied with the way the project was run. What two actions should the project manager take? (Choose two)

- A. Prepare the lessons learned from the project phase.
- B. Deliver the project materials to the users and see if they have any comments
- C. Refer to the communications management plan
- D. Obtain official approval on the new process from the various countries

E. Send a questionnaire to the project participants and seek their feedback.

Answer: ([SHOW ANSWER](#))

NEW QUESTION: 313

You are the project manager for the Heart of Texas casual clothing company. It's introducing a new line of clothing called Black Sheep Ranch Wear. You will outsource the production of this clothing line to a vendor. The vendor has requested a contract SOW. All of the following statements are true except for which one?

- A. As the purchaser, you are required to write the SOW.
- B. The SOW contains a description of the new clothing line.
- C. The vendor requires a SOW to determine whether it can produce the clothing line given the detailed specifications of this product.
- D. The SOW contains the objectives of the project.

Answer: A ([LEAVE A REPLY](#))

Either the buyer or the seller can write the SOW. Sometimes the buyer will write the SOW and the seller might modify it and send it back to the buyer for verification and approval.

NEW QUESTION: 314

An agile team was hired to work on a public service project. The team received a list of vague ideas about the business and now needs to understand, develop, and prioritize a list of functionalities.

Who will be responsible for this task?

- A. Agile team
- B. Agile leader
- C. Product owner
- D. Project owner

Answer: C ([LEAVE A REPLY](#))

NEW QUESTION: 315

According to the PMI, which of the following best describes the differences between programs and projects?

- A. There is no difference between program and project. These terms are interchangeable
- B. Programs are group of project managed together managed together
- C. Programs are used to describe projects in a strong matrix organization
- D. Programs are ongoing operations while projects are temporary and unique

Answer: B ([LEAVE A REPLY](#))

NEW QUESTION: 316

The Closing Process Group includes which of the following Knowledge Areas?

- A. Project Risk Management and Project Procurement Management
- B. Project Integration Management and Project Procurement Management

- C. Project Risk Management and Project Integration Management
- D. Project Integration Management and Project Quality Management

Answer: (SHOW ANSWER)

Section: Closing

Explanation/Reference:

Valid PMP Dumps shared by TrainingQuiz.com for Helping Passing PMP Exam!
TrainingQuiz.com now offer the **newest PMP exam dumps**, the TrainingQuiz.com PMP exam **questions have been updated** and **answers have been corrected** get the **newest** TrainingQuiz.com PMP dumps with Test Engine here: <https://www.trainingquiz.com/PMP-practice-quiz.html> (2045 Q&As Dumps, **40%OFF Special Discount: Exam-Tests**)

NEW QUESTION: 317

In which of the following methods of resolving conflict will the conflict typically reappear again in another form?

- A. Smoothing
- B. Compromising
- C. Collaborating
- D. Confronting

Answer: A (LEAVE A REPLY)

Explanation/Reference:

Explanation:

Smoothing emphasizes areas of agreement while avoiding points of disagreement. It tends to keep peace only in the short term.

NEW QUESTION: 318

Significant differences between the seller's price and your independent estimate may indicate all the following EXCEPT the _____

- A. SOW was not adequate
- B. Seller misunderstood the SOW
- C. Sellers failed to respond
- D. Project team chose the wrong contract type

Answer: (SHOW ANSWER)

Explanation/Reference:

Explanation:

The contract type is typically dictated by the procurement SOW and chosen by the contracting officer.

Independent estimates are a tool and technique in conduct procurements.

NEW QUESTION: 319

What is the critical chain method?

- A. A technique to calculate the theoretical early start and finish dates and late start and finish dates
- B. A schedule compression technique that analyzes cost and schedule trade-offs to determine how to obtain the greatest amount of compression for the least incremental cost
- C. A technique to estimate project duration when there is a limited amount of detailed information about the project
- D. A schedule network analysis technique that modifies the project schedule to account for limited resources

Answer: D ([LEAVE A REPLY](#))

NEW QUESTION: 320

Funding limit reconciliation is a tool and technique of which Project Cost Management process?

- A. Control Costs
- B. Determine Budget
- C. Estimate Costs
- D. Plan Cost Management

Answer: B ([LEAVE A REPLY](#))

NEW QUESTION: 321

An agile team is working on a project that will be launched in six countries. Each country has specific requirements in addition to the base offering. The estimates indicate it will take six months to develop the base offering and an additional month to finalize each country's unique requirements. The expected revenue for the product is the same for each country.

Which release strategy should the project manager recommend?

- A. A quality-based strategy to maximize post-market adoption by releasing the product to the countries with the lowest probability of reporting field issues
- B. A risk-based strategy to maximize the perceived value of the product by launching it to the countries with the lowest technical complexity
- C. A financial-based strategy to reduce the roll-out effort and costs by planning a single, bundled release to all countries at the same time
- D. An iterative-based strategy to maximize value by releasing the product to each country as it is finalized and ready for release in that country

Answer: B ([LEAVE A REPLY](#))

NEW QUESTION: 322

Project contracts generally fall into which of the following three broad categories?

- A. Make-or-buy, margin analysis, fixed-price
- B. Make-or-buy, lump-sum, cost-plus-incentive
- C. Fixed-price, cost reimbursable, time and materials

D. Time and materials, fixed-price, margin analysis

Answer: C ([LEAVE A REPLY](#))

NEW QUESTION: 323

Which type of estimating is used to improve the accuracy of an activity's duration?

- A. Analogous
- B. Parametric
- C. Three-point
- D. What-if scenario analysis

Answer: ([SHOW ANSWER](#))

Section: Executing

NEW QUESTION: 324

During the last sprint review, the main stakeholder complained that the product was missing many features they had been expecting. The project team argued that every increment met the acceptance criteria and was approved by the main stakeholder. The cost performance index (CPI) of the project is 1.15 and the schedule performance index (SPI) is 1.43. What should the project manager do?

- A. Ask the project team to perform the modifications since the project budget and schedule can support them.
- B. Explain to the stakeholder that since the acceptance criteria for every increment were met the project can be closed.
- C. Analyze the reason for the gap in understanding with both sides and negotiate a solution.
- D. Ask the stakeholder to submit a change request to increase the budget and time for the modifications requested.

Answer: C ([LEAVE A REPLY](#))

NEW QUESTION: 325

Which process numerically analyzes the effect of identified risks on overall project objectives?

- A. Plan Risk Management
- B. Plan Risk Responses
- C. Perform Quantitative Risk Analysis
- D. Perform Qualitative Risk Analysis

Answer: C ([LEAVE A REPLY](#))

Section: Initiation

NEW QUESTION: 326

Which types of Organizational Charts can be best used to track project costs:

- A. Organizational Breakdown Structure
- B. Resource Breakdown Structure
- C. Hierarchical-type Organizational Chart

D. Responsibility Assignment Matrix

Answer: ([SHOW ANSWER](#))

Resource Breakdown Structure is a type of hierarchical chart breaks down the project by resource types so that the project manager can see quickly which resources can be grouped together. The RBS does not have to be only for human resources and may include materials, communication technologies, and other types of resources needed to execute the project. A RBS can be aligned with Organization's accounting system.

NEW QUESTION: 327

A project is running on time, but the customer now requests delivery three weeks ahead of schedule without reducing the scope. This will have long-term benefits for the organization. What risk response strategy should the project manager use?

- A. Mitigate
- B. Transfer
- C. Exploit
- D. Accept

Answer: C ([LEAVE A REPLY](#))

NEW QUESTION: 328

The Project Manager and team are planning a banking software project. They are discussing what could go differently than planned on the project. They are also trying to identify warning signs that would show that these events could be on the verge of occurring. What are these warning signs called?

- A. Risk analysis
- B. Triggers
- C. Problem solving
- D. Risks

Answer: B ([LEAVE A REPLY](#))

Section: Mix Questions

Explanation/Reference:

NEW QUESTION: 329

You are the project manager at a large construction company. Your company is under a times and materials contract to build a new shopping center. The estimated cost of project is \$5,000,000. The project sponsor has approved this amount. However, you earned value calculations indicate that the project will be completed on time and under budget by 5,000,000. Based on this calculation your personal profit will decrease by \$10,000. Given the estimated decrease in personal profit, what action should you take?

- A. Suggest to the project sponsor that additional features should be added in order to leverage the entire project
- B. Pad additional tasks to the projected financial outcome to increase the actual project cost

- C. Continue to bill the customer for the full \$5,000,000 as originally estimated.
- D. Communicate the projected financial outcome to the project sponsor

Answer: D (LEAVE A REPLY)

NEW QUESTION: 330

Which of the following is a narrative description of products, services, or results to be delivered by a project?

- A. Project statement of work
- B. Accepted deliverable
- C. Business case
- D. Work performance information

Answer: A (LEAVE A REPLY)

NEW QUESTION: 331

Key stakeholders disagree about the details in the project charter that describe how to deliver project requirements. What tool or technique should the project manager use to resolve this issue and obtain project charter approval?

- A. Expert judgement
- B. Facilitation
- C. Focus groups
- D. Decision making

Answer: B (LEAVE A REPLY)

Section: Monitoring and Controlling

Explanation/Reference:

Valid PMP Dumps shared by TrainingQuiz.com for Helping Passing PMP Exam!

TrainingQuiz.com now offer the **newest PMP exam dumps**, the TrainingQuiz.com PMP exam **questions have been updated** and **answers have been corrected** get the **newest**

TrainingQuiz.com PMP dumps with Test Engine here: <https://www.trainingquiz.com/PMP-practice-quiz.html> (2045 Q&As Dumps, **40%OFF Special Discount: Exam-Tests**)

NEW QUESTION: 332

You are a senior project manager and member of the Project Management Office. The CIO wants you to present a snapshot of the status of various projects going on in the organization. Which of the following charts would be most suitable for the purpose?

- A. Copies of the most recent status report from the team members.
- B. The milestone chart for this project.
- C. The network diagram for this project.
- D. The project charter.

Answer: ([SHOW ANSWER](#))

NEW QUESTION: 333

If your project is under budget, your cost variance (CV) is:

- A. 1
- B. Positive
- C. -1
- D. Negative

Answer: B ([LEAVE A REPLY](#))

NEW QUESTION: 334

The project sponsor recently requested that a vendor begins working toward adopting a hybrid approach. In response, the vendor hired a project manager experienced in agile for the project. What does that project manager need to do to make the team work in a collaborative way?

- A. Update the issue log.
- B. Allocate time to mentor the team.
- C. Identify any training gaps
- D. Request the project management office (PMO) for a team of mentors.

Answer: B ([LEAVE A REPLY](#))

NEW QUESTION: 335

Which of the following is true about procurement documents?

- A. b and c
- B. Invitation for Bid and Request for Proposal are two examples of procurement documents.
- C. Procurement documents should be structured to facilitate accurate and complete responses from prospective sellers.
- D. Procurement documents are used to solicit proposals from prospective sellers.
- E. all of the above

Answer: E ([LEAVE A REPLY](#))

NEW QUESTION: 336

A project manager must manage a virtual application control software team that is culturally and geographically diverse. The project manager wants to promote open collaboration in a Realtime manner.

What should the project manager do?

- A. Promote the use of remote site syndication.
- B. Provide a software for instant messaging.
- C. Document all information on the team wiki.
- D. Facilitate regular conference calls.

Answer: C ([LEAVE A REPLY](#))

NEW QUESTION: 337

During the design phase of a project the project manager notices that the schedule performance index (SPI) is 1.8 and the cost performance index (CPI) is 0.1. In a weekly meeting with top management, the project manager reports concerns about these indicators. However, the most concerned person was the project sponsor who said that if the trend continues, they will be forced to prematurely close the project. What should the project manager do?

- A. Monitor the project sponsor but understand that it is normal to spend more money in the design phase of a project.
- B. Stop crashing the schedule.
- C. Use a resource-levelling technique.
- D. Manage the project sponsor closely and revise the project's resource management plan to improve indicators.

Answer: ([SHOW ANSWER](#))

NEW QUESTION: 338

Expected monetary value (EMV) is computed by which equation?

- A. Value of each possible outcome multiplied by probability of non-occurrence.
- B. Value of each possible outcome multiplied by probability of occurrence.
- C. Multiplying the value of each possible outcome by the probability of occurrence and adding the products together.
- D. Multiplying the value of each possible outcome by the probability of non-occurrence and adding the products together.

Answer: ([SHOW ANSWER](#))

NEW QUESTION: 339

What does a CPI value greater than 1.0 indicate?

- A. Cost right at the estimated value.
- B. Cost under the estimated value.
- C. Cost right at the actual value.
- D. Cost over the estimated value.

Answer: B ([LEAVE A REPLY](#))

Section: Executing

NEW QUESTION: 340

The process of identifying and documenting relationships among the project activities is known as:

- A. Control Schedule.
- B. Sequence Activities.
- C. Define Activities.
- D. Develop Schedule.

Answer: B ([LEAVE A REPLY](#))

Section: Closing

NEW QUESTION: 341

At the end of project execution, a project manager has retained some team members. What should the team be primarily focused on doing at this point?

- A. Assisting with clean up, site restoration, commissioning, and personnel training
- B. Supporting administrative project closure procedures as per company policies
- C. Operating the newly completed facilities until the owners are fully competent
- D. Providing support as part of the warranty period associated with the handover

Answer: ([SHOW ANSWER](#))

Section: Executing

Explanation/Reference:

NEW QUESTION: 342

The basic elements of communication include:

- A. Listening, talking and sign language.
- B. Communicator, encoding, message, medium, decoding, receiver, and feedback
- C. Clarity of speech and good listening habits
- D. All of the other alternatives apply
- E. Reading, writing and listening

Answer: ([SHOW ANSWER](#))

NEW QUESTION: 343

You are the project manager in the I.T. department of a major hospital. Your current project involves developing a web-based interface for legacy mainframe patient-tracking application. Your current project has recently experienced a change where many of the agreed-upon WBS elements were modified as a result. Which type of change has occurred within your project?

- A. Project change
- B. Schedule change
- C. Quality change
- D. Scope change
- E. WBS update

Answer: ([SHOW ANSWER](#))

NEW QUESTION: 344

Recording and reporting information regarding when appropriate configuration information should be provided and regarding the status of proposed and approved changes effectively is done through_____

- A. Configuration status accounting
- B. Configuration verification and audit
- C. Project management methodology

D. A project management information system (PMIS)

Answer: A (LEAVE A REPLY)

Section: Mix Questions

Explanation:

Configuration status accounting captures, stores, and accesses the needed configuration information to manage products and product information effectively.

NEW QUESTION: 345

Collocation can mean:

A. Active team members may be at different physical locations, but meet on a regular basis.

B. b and c

C. A war room is established where team members can meet periodically.

D. a and c

E. All, or almost all, team members are moved to a central physical location for the life of the project.

Answer: D (LEAVE A REPLY)

NEW QUESTION: 346

Assume you have identified your stakeholders and are preparing your stakeholder management plan. You are fortunate that your team is a collocated team as you are working on an internal project to reorganize your IT Department so it is focused more on its customers. The project sponsor is the Chief Operating Officer, and the IT Department Director was surprised as she thought all was well. However, you notice when planning meetings are held, the Chief Financial Officer never attends. You feel since IT affects the entire company, all the senior leaders need some type of involvement. You therefore feel the Chief Financial Officer may be_____

A. Resistant

B. Unaware

C. Uninterested

D. Satisfied

Answer: A (LEAVE A REPLY)

Explanation/Reference:

Explanation:

Since the Chief Financial Officer has financial responsibility for all of the company's work, in preparing a stakeholder engagement strategy, he or she probably is aware of this project, and probably is resistant to change, perhaps feeling resources could be better spent on other initiatives.

Valid PMP Dumps shared by TrainingQuiz.com for Helping Passing PMP Exam!

TrainingQuiz.com now offer the **newest PMP exam dumps**, the TrainingQuiz.com PMP exam

questions have been updated and answers have been corrected get the **newest** TrainingQuiz.com PMP dumps with Test Engine here: <https://www.trainingquiz.com/PMP-practice-quiz.html> (2045 Q&As Dumps, **40%OFF Special Discount: Exam-Tests**)

NEW QUESTION: 347

You are a project manager responsible for the construction of a new office complex. You are taking over for a project manager who recently left the company. The prior project manager completed the scope statement and scope management plan for this project. In your interviews with some key team members, you conclude which of the following?

- A.** They understand that the scope statement describes how the high-level deliverables and requirements will be defined and verified.
- B.** They understand that the scope management plan describes how project scope will be defined and verified and used to control project scope.
- C.** They understand that the scope management plan is deliverables oriented and includes cost estimates and stakeholder needs and expectations.
- D.** They understand that the scope statement assesses the stability of the project scope and outlines how scope will be verified and used to control changes.

Answer: B (LEAVE A REPLY)

The scope management plan describes how project scope will be defined and verified, how the scope statement will be developed, how the WBS will be developed, and how project scope will be controlled.

NEW QUESTION: 348

You are in the process of estimating the number of work periods that will be needed to complete individual schedule activities. All of the following are tools/ techniques you can use EXCEPT:

- A.** Estimating duration by multiplying the quantity of work to be performed by productivity rate
- B.** Estimating duration from a previous, similar schedule activity based on historical information and expert judgment
- C.** Estimating duration by calculating the average of three duration estimates (most likely, optimistic, pessimistic)
- D.** Estimating duration by calculating multiple project durations with varying sets of activity assumptions using Monte Carlo analysis
- E.** Estimating duration by using contingency reserves

Answer: D (LEAVE A REPLY)

NEW QUESTION: 349

All the following statements about Cost Baseline are correct EXCEPT:

- A.** It is used to measure and monitor project performance
- B.** It is a time phased budget
- C.** All projects have one cost baseline
- D.** To measure disbursements, a spending plan can be used as a cost-baseline

Answer: C ([LEAVE A REPLY](#))

NEW QUESTION: 350

Due to increased price volatility a vendor asks the project manager to make a price change that will affect the project contract What should the project manager do next?

- A. Execute the approved change
- B. Evaluate the impact, then update the risk register project management plan and budget
- C. Ask the change control board (CCB) for approval
- D. Submit a change request and analyze the impact

Answer: ([SHOW ANSWER](#))

NEW QUESTION: 351

In a multinational multi location project with virtual teams a project manager has established a project baseline The project manager discovers that multiple risk elements have appeared. The project manager did not foresee these risks during the planning stage of the project.

What should the project manager calculate to address this critical budgetary situation? (Choose two)

- A. Currency exchange rate
- B. Benefits management control in the project
- C. Integrated change control in the project
- D. Mitigation control in the project
- E. Contingency control in the project and rebaseline

Answer: C,E ([LEAVE A REPLY](#))

NEW QUESTION: 352

An intentional activity to modify a nonconforming product or product component is called:

- A. defect repair
- B. work repair
- C. corrective action
- D. preventive action

Answer: ([SHOW ANSWER](#))

Section: Executing

NEW QUESTION: 353

Which of the following is a tool and technique used in all processes within Project Integration Management?

- A. Expert judgment
- B. Records management system
- C. Issue log
- D. Project management software

Answer: A ([LEAVE A REPLY](#))

NEW QUESTION: 354

Project management processes are:

- A. Discrete elements with well-defined interfaces.
- B. Applied globally and across all industry groups.
- C. Project phases, applied as required in different projects.
- D. Static; they must not change across different projects.

Answer: ([SHOW ANSWER](#))

NEW QUESTION: 355

All of the following statements are true regarding the request seller responses process EXCEPT:

- A. The tool/technique of this process are weighting systems, independent estimates, and screening systems
- B. The process involves obtaining responses from prospective sellers on how project requirements can be satisfied
- C. The process is a part of the project executing process group
- D. The output of this process include proposals and qualified sellers list
- E. The prospective sellers, normally at no direct cost to the project, expend most of the actual effort in this process

Answer: A ([LEAVE A REPLY](#))

NEW QUESTION: 356

All the following statements are true regarding communication management plan except:

- A. The communication management plan provides information on stakeholders communication requirements and glossary of common terminology
- B. Communication management plan is out put of communication planning process
- C. None of choices are correct
- D. The communication management plan is an input to information distribution process

Answer: C ([LEAVE A REPLY](#))

NEW QUESTION: 357

project manager for a defense software application has a culturally and gender-diverse team with a short project time line Considering the project will be stressful what skill should the project manager use to monitor the team's performance?

- A. Emotional intelligence
- B. Conflict resolution
- C. Coercion
- D. Negotiating

Answer: A ([LEAVE A REPLY](#))

NEW QUESTION: 358

Which of the following is an input to Direct and Manage Project Execution?

- A. Approved change requests
- B. Work performance information
- C. Implemented defect repair
- D. Requested changes

Answer: D ([LEAVE A REPLY](#))

NEW QUESTION: 359

Which of the following is a common characteristic of most project life cycle descriptions?

- A. Cost and staffing are low at the start, higher towards the end, and drop rapidly as the project nears completion.
- B. The probability of successfully completing the project is highest at the start of the project.
- C. Both:

Cost and staffing are low at the start, higher towards the end, and drop rapidly as the project nears completion.

And:

The probability of successfully completing the project is highest at the start of the project.

- D. Stakeholders have the most influence on the final characteristics of the product at the end of the project.

Answer: ([SHOW ANSWER](#))

NEW QUESTION: 360

You are the project manager for the company that sells online music. Your project is to develop a new content management system that will not only manage all users purchases and downloads, but will automatically learn the users music interests in order to make future product recommendations. In addition your content management system must scale to support millions of concurrent music downloads a day.

Your team has made significant progress on the project. You are preparing the performance of a project to date and have calculated the following measurements.

PV=4,000 EV= 3,500 AC= 3,000

What is the SPI of this project?

- A. 1.16
- B. 0.875
- C. 1.333
- D. 0.75
- E. 1.14

Answer: B ([LEAVE A REPLY](#))

NEW QUESTION: 361

During the daily standup meeting that is assessing progress against the current sprint, a team member reports some delays due to a component managed by an external vendor. How should the project manager address the team member's concern?

- A. Update the communications management plan to prevent future reoccurrence.
- B. Implement fast tracking to reduce the impact of the delay on the sprint.
- C. Ask the team member to resolve the issue independently to minimize further delays.
- D. Ask the team member to provide details to address the issue with the vendor.

Answer: ([SHOW ANSWER](#))

Valid PMP Dumps shared by TrainingQuiz.com for Helping Passing PMP Exam!
TrainingQuiz.com now offer the **newest PMP exam dumps**, the TrainingQuiz.com PMP exam **questions have been updated** and **answers have been corrected** get the **newest** TrainingQuiz.com PMP dumps with Test Engine here: <https://www.trainingquiz.com/PMP-practice-quiz.html> (2045 Q&As Dumps, **40%OFF** Special Discount: **Exam-Tests**)

NEW QUESTION: 362

Requirements for formal contract acceptance and closure usually are defined in the _____

- A. Proposal
- B. Statement of work
- C. Contract terms and conditions
- D. Procurement audit report

Answer: C ([LEAVE A REPLY](#))

Section: Mix Questions

Explanation:

The contract terms and conditions typically describe the procedure the buyer will employ to close the contract.

NEW QUESTION: 363

A benefit of using virtual teams in the Acquire Project Team process is the reduction of the:

- A. costs associated with technology
- B. costs associated with travel
- C. possibility of communication misunderstandings
- D. cultural differences of team members

Answer: B ([LEAVE A REPLY](#))

NEW QUESTION: 364

Your project sponsor has asked you to produce a Risk Management Plan for your current project. Which of the following best describes how you should tailor the plan to your project?

- A. The plan must include the predefined roles and responsibilities as they relate to risk management.
- B. The plan must be predefined templates as defined by the organization
- C. The plan must include the predefined risk management policies as they relate to the organization
- D. The plan must ensure that the level of details and risk management efforts are commensurate with the level of risk and importance of the project

Answer: D (LEAVE A REPLY)

NEW QUESTION: 365

Parametric estimates are based on variables such as:

- A. Project objectives and manpower allocations.
- B. The WBS and similar projects.
- C. Precise measurements and multiple inputs.
- D. Detailed planning and cost restraints.
- E. Physical characteristics and historical data.

Answer: E (LEAVE A REPLY)

NEW QUESTION: 366

You are working on a project with 15 stakeholders. The number of communication channels on this project is _____

- A. 15
- B. 105
- C. 210
- D. 225

Answer: B (LEAVE A REPLY)

Section: Mix Questions

Explanation:

The formula for determining the number of communication channels is $n(n - 1)/2$, where n = the number of stakeholders: $15(15 - 1)/2 = (15)(14)/2 = 105$. It is important to note that project managers must plan the project's communications requirements carefully, limiting who will communicate with whom given the potential for confusion when multiple communications channels can exist.

NEW QUESTION: 367

In the Develop Project Team process, which of the following is identified as a critical factor for a project's success?

- A. Team meetings
- B. Subcontracting teams
- C. Virtual teams
- D. Teamwork

Answer: ([SHOW ANSWER](#))

Section: Closing

NEW QUESTION: 368

A major project deliverable is completed. What should the project manager and team do to confirm that specifications have been met?

- A. Check the organizational process assets.
- B. Validate the quality audit reports.
- C. Verify the scope.
- D. Perform quality control

Answer: ([SHOW ANSWER](#))

Section: Closing

Explanation

NEW QUESTION: 369

During project planning, a project manager meets with several departments to organize brainstorming sessions. Which process does this describe?

- A. Create Requirements Documentation
- B. Collect Requirements
- C. Identify Stakeholders
- D. Define Scope

Answer: B ([LEAVE A REPLY](#))

NEW QUESTION: 370

Which of the following inputs is required for the WBS creation?

- A. Project Quality Plan
- B. Project Schedule Network
- C. Project Management Software
- D. Project Scope Management Plan

Answer: D ([LEAVE A REPLY](#))

Section: Planning

NEW QUESTION: 371

A project manager performs an audit of a subcontracted supplier to determine if scope, quality, and time requirements are being met. What process is the project manager using.

- A. Conduct Procurements
- B. Plan Procurement Management
- C. Control Procurements
- D. Procurement strategy

Answer: D ([LEAVE A REPLY](#))

NEW QUESTION: 372

The Administer Procurements process is in which of the following Project Management Process Groups?

- A. Executing
- B. Monitoring and Controlling
- C. Initiating
- D. Planning

Answer: B ([LEAVE A REPLY](#))

NEW QUESTION: 373

Your project team is on its way to finish work on the project, while you have the impression that a staff member is already negotiating the next assignment in another project. You are afraid that the person may come under pressure to start working on the other job before she has finished her work for your project. Her task is very complex, and it would be hard for someone else to take up the partial results and finish them.

What action is most likely to resolve the situation?

- A. Use your network of project managers to find another assignment for the person which allows for smooth transition and does not conflict with your needs.
- B. Have a meeting with the entire team and discuss the person's expected early leave. Use team dynamics to buy in the commitment from the person to finish work orderly.
- C. Have a private meeting with the person and discuss your observations. Make the person aware of the contract and of the legal consequences of unfinished work.
- D. Ignore your observations and let the team member do her job. It is quite uncommon that staff drops work for a project before it is completely finished.

Answer: A ([LEAVE A REPLY](#))

NEW QUESTION: 374

Which type of chart is a graphic representation of a process showing the relationships among process steps?

- A. Bar
- B. Flow
- C. Control
- D. Pareto

Answer: B ([LEAVE A REPLY](#))

NEW QUESTION: 375

Match the project situation on the left to the meeting on the right where the situation could occur.

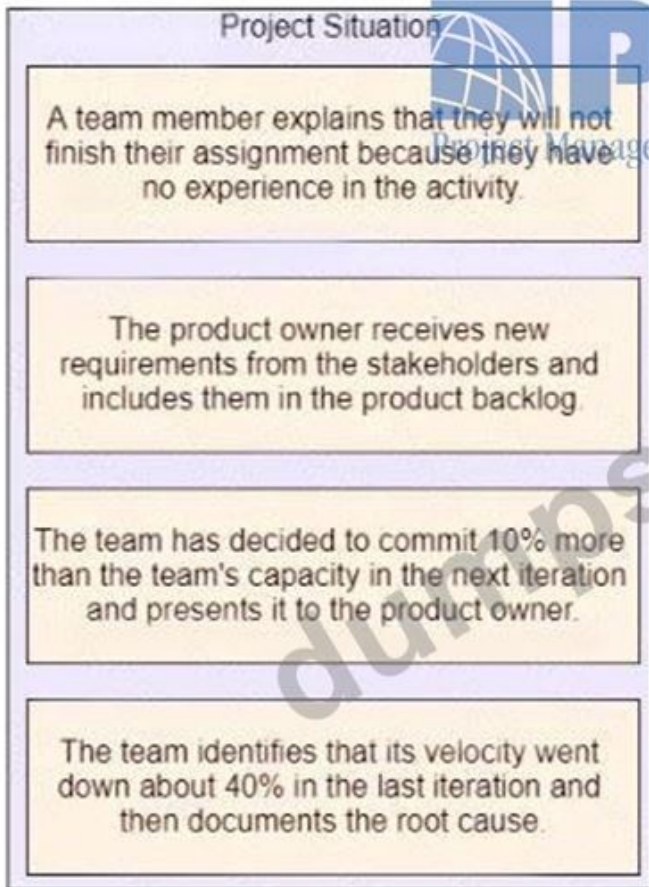

Answer:

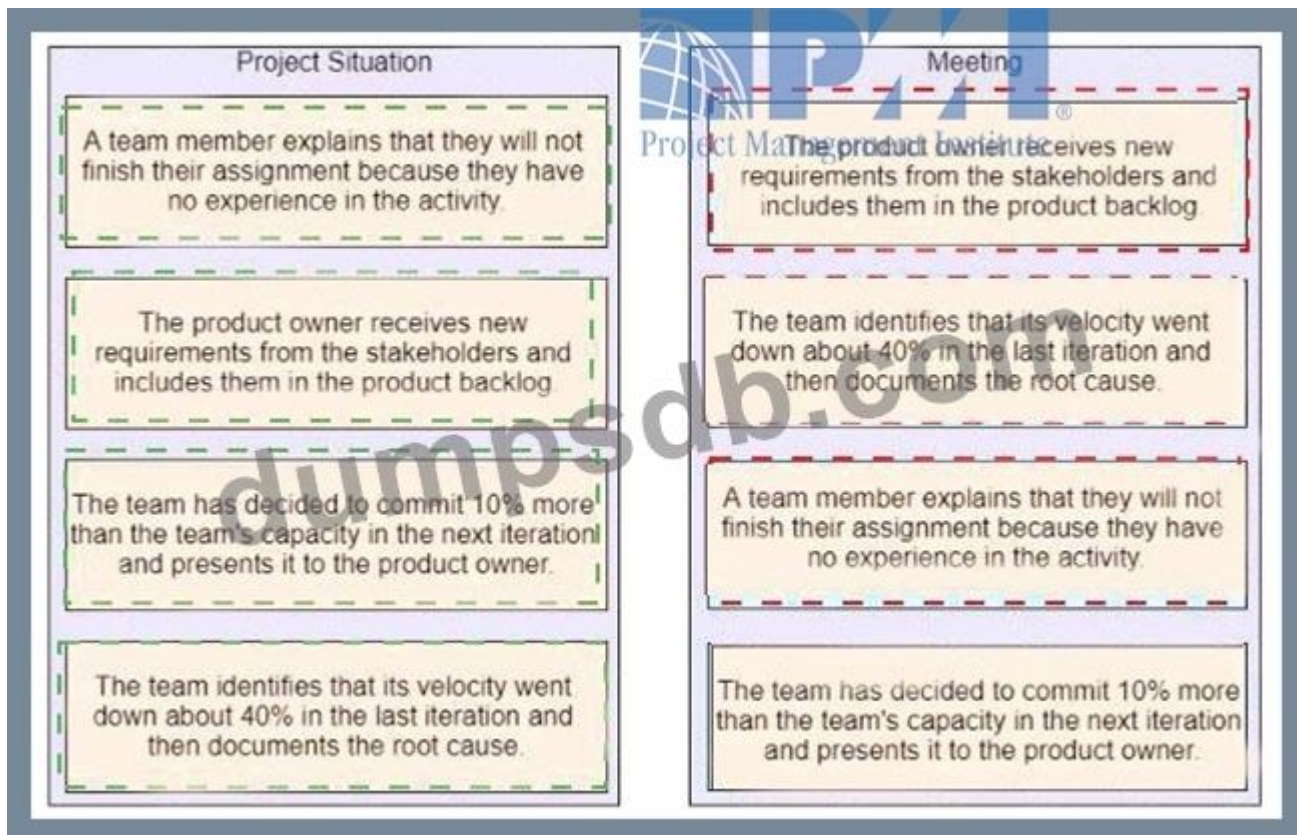

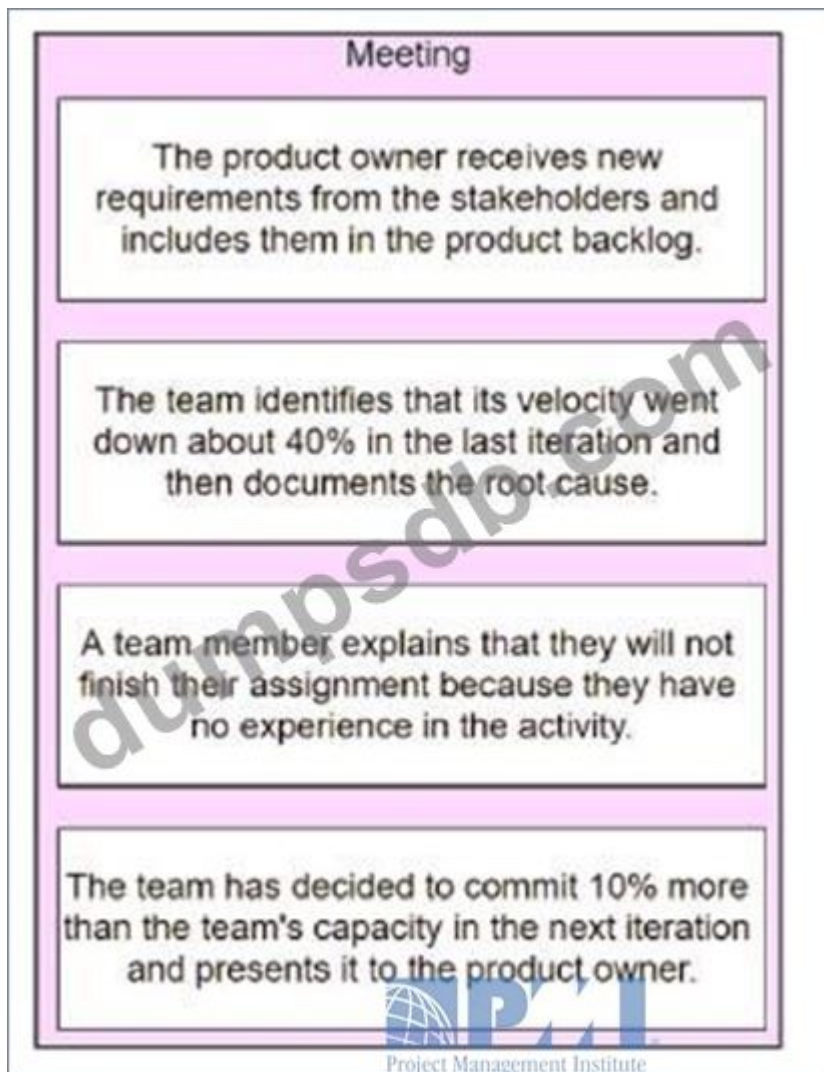

NEW QUESTION: 376

What is a tool to improve team performance?

- A. Performance reports
- B. External feedback
- C. Co-location
- D. Staffing plan

Answer: C ([LEAVE A REPLY](#))

Valid PMP Dumps shared by TrainingQuiz.com for Helping Passing PMP Exam!

TrainingQuiz.com now offer the **newest PMP exam dumps**, the TrainingQuiz.com PMP exam **questions have been updated** and **answers have been corrected** get the **newest** TrainingQuiz.com PMP dumps with Test Engine here: <https://www.trainingquiz.com/PMP-practice-quiz.html> (2045 Q&As Dumps, **40%OFF** Special Discount: **Exam-Tests**)

NEW QUESTION: 377

At what stage in a project are Administrative closure activities performed?

- A. When the product is complete.
- B. The completion of execution phase.
- C. The customer acceptance phase.
- D. Upon the completion of each phase in the project.

Answer: ([SHOW ANSWER](#))

NEW QUESTION: 378

You are in the process of identifying and documenting the logical relationships among schedule activities. Which of the following are NOT outputs to this process?

- A. Milestones list
- B. Activity attributes updates
- C. Activity list updates
- D. Project schedule network diagram
- E. Requested changes

Answer: ([SHOW ANSWER](#))

NEW QUESTION: 379

What quality control tool graphically represents how various elements of a system interrelate?

- A. Run chart
- B. Control chart
- C. Pareto chart
- D. Flowchart

Answer: D ([LEAVE A REPLY](#))

NEW QUESTION: 380

Which of the following can the project manager use as a means of measuring project team effectiveness?

- A. Turnover of personnel
- B. Efficiency of the team
- C. Sponsor-approved salary increases
- D. Grievances
- E. Absenteeism

Answer: B ([LEAVE A REPLY](#))

NEW QUESTION: 381

A junior project manager is excited to start working on their first project with a telecommunications company, A senior project manager has decided to educate the junior project manager on the challenges of project management and how to achieve success.

Which three artifacts should the senior project manager tell the junior project manager to utilize to ensure project success? (Choose three)

- A. Organizational process assets (OPAs)

- B. Project management plan
- C. Historical issue logs
- D. Lesson learned registers from past projects
- E. Project scope statement

Answer: C,D,E ([LEAVE A REPLY](#))

NEW QUESTION: 382

A project manager already has a good understanding of the expectations of the project stakeholders. What action should the project manager take next to effectively plan to project?

- A. Assess required competencies against resource availability.
- B. Conduct a kick-off meeting with the team.
- C. Discover needs and decompose them into requirements.
- D. Determine the project budget and funding sources.

Answer: C ([LEAVE A REPLY](#))

Section: Planning

NEW QUESTION: 383

The major difference between the project coordinator and project expeditor forms

- A. Strong commitment to the project usually does not exist in the project expeditor form of organization
- B. The project coordinator cannot personally make or enforce decisions
- C. The project expeditor acts only as an intermediary between management and the project team
- D. The project coordinator reports to a higher-level manager in the organization

Answer: ([SHOW ANSWER](#))

Explanation/Reference:

Explanation:

The relative position of the project coordinator in the organization is thought to lead to an increased level of authority and responsibility.

NEW QUESTION: 384

A project team has a dedicated scoping phase for their project where all subject matter experts are meeting together with a trained facilitator. They have interviewed each person in the room to gather ideas for functionality and are now voting on them to put them in order, ranking the most useful ideas so they can be taken up for further brainstorming. The group's activities are an example of:

- A. Brainstorming
- B. Focus group
- C. The Majority technique
- D. The nominal group technique.

Answer: D ([LEAVE A REPLY](#))

NEW QUESTION: 385

A project manager noticed that the functional manager is not cooperating with staff assignment schedules and is always finding excuses not to release the requested staff.

What should the project manager do first?

- A. Check with human resources (HR) regarding the availability of staff.
- B. Have a direct talk with the functional manager to understand the reasons behind their attitude.
- C. Ask the leadership team for help obtaining the needed staff.
- D. Evaluate the impact caused by the delay of forming the team and confront the functional manager.

Answer: ([SHOW ANSWER](#))

NEW QUESTION: 386

A project manager is assigned to a project within a program. The high-level requirements of the project are known, but the priorities of some of the requirements are uncertain as they are interdependent on some other pipeline projects within the program.

How should the project manager prepare for the next steps of the project?

- A. Wait for the other project estimates before planning the schedule
- B. Ask the project management office (PMO) to estimate the tasks for all the projects and share the project management plan
- C. Prioritize and estimate the milestones for the high-level requirements based on historical data
- D. Escalate to the management team to increase the timeline based on the complexity of the project

Answer: C ([LEAVE A REPLY](#))

NEW QUESTION: 387

Which of the following theories are illustrated by the principle: "Employees who believe that their efforts will lead to effective performance and who anticipate important rewards for their accomplishments become productive stay productive."

- A. Ouchi's Theory Z
- B. The X-Y theory.
- C. Herzberg's theory.
- D. Maslow's theory.
- E. The expectancy theory.

Answer: E ([LEAVE A REPLY](#))

NEW QUESTION: 388

During a project management planning meeting two key stakeholders have conflicting interests. One requires added time to implement a new system to support the project, while the other refuses to delay the launch date due to previous time commitments.

What should the project manager do?

- A. Determine how to achieve the finished system by the launch date

- B. Negotiate a delayed launch
- C. Collaborate with both stakeholders.
- D. Meet with the project sponsor.

Answer: C ([LEAVE A REPLY](#))

NEW QUESTION: 389

You have been assigned as a project leader and must first review the statement of work provided by the customer. Which of the following is most often overlooked?

- A. Other subcontractor interface requirements
- B. Customer-furnished equipment and facilities
- C. Data item deliverables
- D. Customer-imposed milestones
- E. Long-lead procurement items

Answer: ([SHOW ANSWER](#))

NEW QUESTION: 390

You are a part of project software team responsible for developing a new CRM software application. The project has been ongoing for the past several months. A few members of the project team are currently discussing introducing a significant change to one of the major work packages. After discussions you received a message from the vice president of engineering informing you of the project changes, and are asked to complete the necessary paperwork in order to process the change. This is an example of:

- A. A configuration management system
- B. A project expediter role
- C. A change control system
- D. Managing stakeholder need
- E. Management by objectives

Answer: B ([LEAVE A REPLY](#))

NEW QUESTION: 391

Which type of dependency is established based on knowledge of best practices within a particular application area or some unusual aspect of the project in which a specific sequence is desired, even though there may be other acceptable sequences?

- A. Internal
- B. Mandatory
- C. External
- D. Discretionary

Answer: ([SHOW ANSWER](#))

Valid PMP Dumps shared by TrainingQuiz.com for Helping Passing PMP Exam!
TrainingQuiz.com now offer the **newest PMP exam dumps**, the TrainingQuiz.com PMP exam **questions have been updated** and **answers have been corrected** get the **newest** TrainingQuiz.com PMP dumps with Test Engine here: <https://www.trainingquiz.com/PMP-practice-quiz.html> (2045 Q&As Dumps, **40%OFF** Special Discount: **Exam-Tests**)

NEW QUESTION: 392

During planning, a project team documented the possibility that new hardware could arrive up to 45 days late and delay the project's delivery date. One month into the project, the manufacturer notifies the project manager that the hardware will be shipped 20 days sooner than anticipated. What should the project manager do next?

- A. Update the risk register
- B. Adjust the procurement statement of work (SOW)
- C. Issue a change request
- D. Modify the budget.

Answer: A (LEAVE A REPLY)

NEW QUESTION: 393

The number of potential communication channels for a project with 5 stakeholders is:

- A. 10.
- B. 12.
- C. 20.
- D. 24.

Answer: A (LEAVE A REPLY)

Section: Executing

NEW QUESTION: 394

Recording and reporting information regarding when appropriate configuration information should be provided and regarding the status of proposed and approved changes effectively is done through_____

- A. Configuration status accounting
- B. Configuration verification and audit
- C. Project management methodology
- D. A project management information system (PMIS)

Answer: (SHOW ANSWER)

Explanation/Reference:

Explanation:

Configuration status accounting captures, stores, and accesses the needed configuration information to manage products and product information effectively.

NEW QUESTION: 395

The Crosswind broadcasting has recently been awarded a large contract to create a new children's television show. This will require the company to move into a new office complete with production facilities

300% larger than what it presently has. The schedule is tight for this new project, and there can be no delay. The new facility is behind schedule with the sets and production facilities on pace to finish two months late. The company is trying to use an incentive fee to motivate the provider of these services to complete the work as quickly as possible even if it results in a smaller delay. This is an example of what type of risk response?

- A. Avoid
- B. Accept
- C. Transfer
- D. Mitigate

Answer: D (LEAVE A REPLY)

Section: Mix Questions

NEW QUESTION: 396

During execution of an agile project, a project manager realizes the budget is almost completely used, but the project is not close to being completed. What should the project manager do to address this concern?

- A. Review the budget with the project sponsor and ask for an increase to the budget
- B. Review the backlog and find opportunities to reprioritize the work and reduce the project scope
- C. Review the resource management plan and find opportunities to reduce project costs.
- D. Review the project time line and find opportunities to reduce the project schedule.

Answer: B (LEAVE A REPLY)

NEW QUESTION: 397

What is a tool to improve team performance?

- A. Staffing plan
- B. External feedback
- C. Performance reports
- D. Co-location

Answer: D (LEAVE A REPLY)

Section: Executing

NEW QUESTION: 398

Which processtool is conflict management?

- A. manage project team
- B. Plan Human resource Management
- C. Developed project team
- D. Acquire project team

Answer: A ([LEAVE A REPLY](#))

NEW QUESTION: 399

Taking out insurance in relation to risk management is called what?

- A. Transference
- B. Exploring
- C. Mitigation
- D. Avoidance

Answer: A ([LEAVE A REPLY](#))

NEW QUESTION: 400

What is the number of stakeholders, if the project has 28 potential communication channels?

- A. 8
- B. 7
- C. 16
- D. 14

Answer: A ([LEAVE A REPLY](#))

NEW QUESTION: 401

A project manager is assigned to a large construction project with more than 100 project team members. The project manager is having a hard time keeping the project on track and deriving the planned benefits. The project manager wants to make sure that each requirement is linked to the business and project objective.

What should the project manager do?

- A. Add the requirements to the project charter.
- B. Review the requirements on a weekly basis.
- C. Understand the project management plan.
- D. Implement a requirements traceability matrix.

Answer: D ([LEAVE A REPLY](#))

NEW QUESTION: 402

Your project was just completed, accepted, and closed. As is customary for your organization, you conduct a post-implementation audit. The purpose of this audit includes all of the following except for which one?

- A. Documenting the acceptance of the work results
- B. Documenting possible improvements for future projects
- C. Evaluating project goals and comparing them to the project's product
- D. Reviewing successes and failures

Answer: A ([LEAVE A REPLY](#))

Post-implementation audits are similar to lessons learned in that they review and document the project successes and failures, look for possible improvements for future projects, and evaluate the project goals and compare these to the end product.

NEW QUESTION: 403

Which of the following are documented directions to perform an activity that can reduce the probability of negative consequences associated with project risks?

- A. Risk audits
- B. Risk reassessments
- C. Recommended preventive actions
- D. Recommended corrective actions

Answer: ([SHOW ANSWER](#))

NEW QUESTION: 404

What is the purpose of a Preliminary scope statement?

- A. To address and document the characteristics and boundaries of the project and its associated products and services.
- B. To break down the scope of the project into smaller, better manageable components for further planning and estimating.
- C. To formally authorize the project and provide the project manager with the authority to apply organizational resources.
- D. To link the project, which is going to be planned, executed, and monitored/controlled to the ongoing work of the organization.

Answer: A ([LEAVE A REPLY](#))

NEW QUESTION: 405

PMBOI Guide is a standard that describes:

- A. project management processes.
- B. program management and project management processes.
- C. product-oriented processes.
- D. product-oriented and project management processes.

Answer: A ([LEAVE A REPLY](#))

NEW QUESTION: 406

The iterative process of increasing the level of detail in a project management plan as greater amounts of information become available is known as:

- A. Quality assurance.
- B. Predictive planning.
- C. Continuous improvement.
- D. Progressive elaboration.

Answer: ([SHOW ANSWER](#))

Valid PMP Dumps shared by TrainingQuiz.com for Helping Passing PMP Exam!

TrainingQuiz.com now offer the **newest PMP exam dumps**, the TrainingQuiz.com PMP exam **questions have been updated** and **answers have been corrected** get the **newest** TrainingQuiz.com PMP dumps with Test Engine here: <https://www.trainingquiz.com/PMP-practice-quiz.html> (2045 Q&As Dumps, **40%OFF** Special Discount: **Exam-Tests**)

NEW QUESTION: 407

Which project management process groups takes maximum time and resource in a project?

- A. planning
- B. initiation
- C. execution
- D. closing

Answer: C (LEAVE A REPLY)

Execution project management process groups takes maximum time and resource in a project. For project execution you need most of the resources and time.

NEW QUESTION: 408

On a project with multiple international locations, a trend for delays has been flagged. When looking into the issue, the project manager realized that some of the key activities were scheduled over the holiday periods in the overseas offices.

What should the project manager do next?

- A. Update the schedule to reflect the holidays and notify the project sponsor of the delayed completion.
- B. Update the schedule to reflect the holidays and share the workload among offices to mitigate schedule slippage.
- C. Hire additional personnel on a temporary basis to cover the extra workload during the holiday seasons.
- D. Request that the offices in overseas locations work overtime to mitigate schedule slippages.

Answer: A (LEAVE A REPLY)

NEW QUESTION: 409

The degree, amount, or volume of risk that an organization or individual will withstand is called risk:

- A. threshold
- B. management
- C. appetite
- D. tolerance

Answer: (SHOW ANSWER)

NEW QUESTION: 410

Define and sequence following different stages of the Team Development:

- A. Formation
- B. Storming
- C. Norming
- D. Performing.

Answer: A,B,C,D (LEAVE A REPLY)

The order is Forming --> Storming --> Norming --> Performing. The 4 stages of team development is called "Tuckman" model. The name is from Bruce Tuckman who wrote about this model in 1965. Forming: also called floundering - this is the awkward time when a team just comes together and everyone is getting to know each other and each others role(s) on the project. It's time for getting acquainted. Storming: also called conflict - at this stage teams begin to confront issues and other team members. Conflict over goals, priorities, roles - can cause tension and disagreement. It's time of competitive tension. Norming: also called organized - team is now demonstrating cohesiveness and cooperation to meet project objectives. At this stage, teams are better able to handle roadblocks because procedures are established and skills have been developed. It's time for developing procedures and policies. Performing: also called productive - team is performing at a high level and there is mutual trust among the team members. Roles and procedures are accepted, understood and followed. It's now the effective team.

NEW QUESTION: 411

Optimistic 3 days, Pessimistic 9 days, and mostly likely 6 days. What is the standard deviation of this estimation?

A. Method 2: Assume, observations are 3,6,6,6,6,9 (as Optimistic is 3 days, pessimistic is 9 days and most likely is 6 days). Hence, mean = $(3+6+6+6+6+9)/6 = 6$; SD = $\text{Sqrt}[\text{Sum}\{(number - mean)^2\}/(n - 1)]$, where n is sample size. =

$$\text{Sqrt}\left[\frac{(3-6)^2+(6-6)^2+(6-6)^2+(6-6)^2+(9-6)^2}{(6-1)}\right] = \text{Sqrt}\left[\frac{9+0+0+0+9}{5}\right] = \text{Sqrt}\left[\frac{18}{5}\right] = \text{Sqrt}[3.6] = 1.9 \text{ (WRONG? I don't know why?)}$$

B. Method 1: PERT simplifies the calculation of Standard Deviation (SD) = $[\text{Pessimistic Estimate (TP)} - \text{Optimistic Estimate (TO)}] / 6 = (9 - 3) / 6 = 1$

Answer: (SHOW ANSWER)

NEW QUESTION: 412

A project's core team was reassigned to a partially completed project. The new team underestimated the scope and consistently reported that their tasks were on track. The day before a major deliverable was due, the project manager learned that the product would actually be delivered 10 days behind schedule. What could the project manager have done to avoid this situation?

A. Created a more robust schedule that allowed for extra time to recover from underestimating the scope.

B. Maintained standby resources a few days before the due date to fast track the schedule during the storming phase.

C. Used the mitigation defined in the risk management plan to effectively integrate the new team.

D. Empowered the team to secure additional resources if they needed to crash the schedule to meet the deadline

Answer: ([SHOW ANSWER](#))

NEW QUESTION: 413

A company has selected a cross-functional team to develop an innovative digital product to drive the digital transformation project for the business. What should the project manager do to ensure business value is delivered early?

A. Create robust incentives to the team members to encourage speedy delivery.

B. Create a detailed project plan and escalate delays to the functional managers.

C. Break down the deliverables into sprints and deliver value incrementally.

D. Fast track the project and monitor tasks closely to ensure timely delivery.

Answer: ([SHOW ANSWER](#))

NEW QUESTION: 414

Which of the following tools is used in process analysis to determine the underlying causes of defects?

A. Root cause analysis

B. Assumptions analysis

C. Cost-benefit analysis

D. Quality metrics

Answer: ([SHOW ANSWER](#))

Section: Mix Questions

Explanation:

Determining the root cause of the problem means to determine the origin of the problem. What may appear to be the problem on the surface is often revealed, after further analysis, not to be the real cause of the problem. Process analysis includes root cause analysis used to identify as problem, discover the underlying causes that lead to it and develop preventive actions.

NEW QUESTION: 415

The swiftest and most effective communications take place among people with

A. advanced degrees

B. common points of view

C. dissimilar interests

D. good encoding skills

E. the ability to reduce perception barriers

Answer: **B** ([LEAVE A REPLY](#))

NEW QUESTION: 416

Sharing good practices introduced or implemented in similar projects in the organization and/or industry is an example of:

- A. quality audits
- B. statistical sampling
- C. process analysis
- D. benchmarking

Answer: A ([LEAVE A REPLY](#))

NEW QUESTION: 417

The scope baseline consists of:

- A. The Scope Management Plan, the Preliminary Scope Statement, and the WBS.
- B. The Scope Management Plan, the Project Scope Statement, and the WBS
- C. The Project Scope Statement, the WBS, and the WBS Dictionary
- D. The Scope Management Plan, the WBS, and the WBS Dictionary

Answer: ([SHOW ANSWER](#))

The scope baseline is made up of the Project Scope Statement and the WBS and the WBS Dictionary. The WBS Dictionary is considered a supporting document to the WBS, so if the WBS were to change, then the dictionary would, too.

NEW QUESTION: 418

Cost and schedule data are usually integrated because:

- A. optimized project cash flow can affect financial requirements
- B. they control escalation allowances
- C. they provide MIS with an integrated system to produce reports
- D. they account for omissions in the definitive estimate
- E. they predict future performance

Answer: ([SHOW ANSWER](#))

NEW QUESTION: 419

Projects may be chartered by all of the following bodies, except?

- A. A portfolio management body
- B. A program management body
- C. The project team
- D. The organization

Answer: C ([LEAVE A REPLY](#))

NEW QUESTION: 420

The product scope description is documented as part of the project's scope statement. It is important to include it because it_____

- A. Facilitates the project acceptance process

- B. Describes specific constraints associated with the project
- C. Progressively elaborates characteristics
- D. Shows various alternatives considered

Answer: C (LEAVE A REPLY)

Explanation/Reference:

Explanation:

The project scope statement describes the deliverables and the work required to create them. It also provides a common understanding of the scope among stakeholders. The product scope statement is a key component as it progressively elaborates the characteristics of the product, service, or result in the project charter and requirements documentation.

NEW QUESTION: 421

You are being hired to manage a highway construction project for a contractor working for Smith County. The sponsor is a project officer who works for the Smith County municipal government. You have three separate teams working all three shifts, with a separate foreman for each team. Each team has members from two different unions, and each union has its own representative. Who is the BEST person to approve the project charter?

- A. The team foreman
- B. The project manager
- C. The two union representatives
- D. The Smith County project officer

Answer: D (LEAVE A REPLY)

Since the Smith County project officer is the sponsor, he's the person who is best suited to signing the charter. A project charter is typically approved and signed by the sponsor. Some projects are approved by key stakeholders, but they are never approved by project managers (since the project manager is only granted authority once the project is signed) or team members.

Valid PMP Dumps shared by TrainingQuiz.com for Helping Passing PMP Exam!

TrainingQuiz.com now offer the **newest PMP exam dumps**, the TrainingQuiz.com PMP exam **questions have been updated** and **answers have been corrected** get the **newest**

TrainingQuiz.com PMP dumps with Test Engine here: <https://www.trainingquiz.com/PMP-practice-quiz.html> (2045 Q&As Dumps, **40%OFF Special Discount: Exam-Tests**)

NEW QUESTION: 422

A division manager wants to transfer a key team member off of the project. This may impact the project delivery schedule listed in the contract What should the project manager do in this situation?

- A. Discuss this situation with the customer
- B. Modify the project schedule.

- C. Discuss it with the project sponsor
- D. Submit a change request.

Answer: D ([LEAVE A REPLY](#))

NEW QUESTION: 423

Which of the following would most likely not be an essential objective of a project team kick-off meeting

- A. Obtain individual and group commitments
- B. Identify project problem areas
- C. Create a project technology master plan
- D. Get team members to know one another
- E. Identify the project coordinator

Answer: C ([LEAVE A REPLY](#))

NEW QUESTION: 424

What should the team consider to be most important while creating the probability and impact matrix to support the project risk analysis?

- A. Project scope and project deliverables
- B. Schedule and budget contingencies and reserves
- C. Possible effect on the objectives of the project
- D. Interactions that will occur in the project

Answer: ([SHOW ANSWER](#))

NEW QUESTION: 425

Which of the following is not one of the five project management process group?

- A. Executing process group
- B. Monitoring and controlling the group
- C. Fast tracking
- D. Planning process group
- E. Initiating process group

Answer: C ([LEAVE A REPLY](#))

NEW QUESTION: 426

The sponsor of your project is particularly interested in reviewing the roles of different stakeholders on the project. As a project manager, you should direct the sponsor of the project to which one of the following documents?

- A. Stakeholder engagement assessment matrix
- B. Project Team Directory
- C. Stakeholder Management Plan
- D. Stakeholder Register

Answer: D ([LEAVE A REPLY](#))

NEW QUESTION: 427

A project team is implementing a hosted system for a third party. Just before going live, the customer asks the project team to include additional functionality. The project team identified risks to the delivery date and informed the project manager that some of the requested functions are in conflict with the agreed scope.

What should the project manager do?

- A. Discuss with the team, estimate the effort, and raise a change request.
- B. Discuss with the customer the risks identified and team's concerns.
- C. Ask the customer to go live and add the new functionality in the backlog.
- D. Ask the team to deliver the functionality on the agreed go-live date.

Answer: A (LEAVE A REPLY)

NEW QUESTION: 428

You are presented the following schedule data regarding various project activities on a critical path:

Exhibit:

Activity	Original Duration (Months)	Crash Duration (Months)	Time Savings	Original Cost	Cost W/ Crashing
S	10	8	2	\$ 3,000	\$ 12,000
T	15	14	1	\$13,000	\$ 15,000
U	6	5	1	\$ 3,000	\$ 10,000
V	8	6	2	\$13,000	\$ 13,000
X	22	18	4	\$23,000	\$ 29,000

You are told that the project has negative float of 4 months. What is the minimum amount it will cost to save four months by crashing the project?

- A. 6,000
- B. 9,000
- C. 7,000
- D. 10,000
- E. 8,000

Answer: A (LEAVE A REPLY)

NEW QUESTION: 429

Which of the following is true regarding product scope descriptions?

- A. The product description is a component of an input of the Develop Project Charter process. It describes the characteristics of the product, service, or result and contains less detail in the early phases of the project.
- B. The product description is a component of an input of the Preliminary Scope Statement process. It describes the characteristics of the product, service, or result and contains a good deal of detail in the early phases of the project.

C. The product scope description is a component of the output of the Develop Project Charter process. It describes the characteristics of the product, service, or result and contains a good deal of detail in the later phases of the project.

D. The product description is a component of the output of the Preliminary Scope Statement process. It describes the characteristics of the product, service, or result and contains less detail in the early phases of the project.

Answer: (SHOW ANSWER)

The product description is a component of the project SOW, which is an input of both the Develop Project Charter and Preliminary Scope Statement processes. It describes the characteristics of the product, service, or result and contains less detail in the early phases of the project and more detail as the project progresses.

NEW QUESTION: 430

A product development manager, who is unsure of an initial prototype's requirements, is upset to learn that it must be compared in two months. What should the project manager have done to avoid this?

A. Ensured that the right resources were assigned to the project

B. Included the product development manager in the communications management plan

C. Obtained stakeholder agreement on the project's schedule and deliverables

D. Obtained the required resource from the procurement manager

Answer: C (LEAVE A REPLY)

NEW QUESTION: 431

You are the project manager at a large automaker in Japan. Your project involves designing the next generation 4-wheel drive Sport Utility vehicle for the Asian market. A new fuel-efficient engine design is required as part of your project. Unfortunately, your project team did not have the necessary expertise to design and manufacture a new fuel-efficient engine. Hence, your company plans to subcontract all the engine designs to an outside manufacturer in Europe. During your initial visits to European partners, you were presented with an expensive gift. You were told that this is local custom to give such gifts to business partners during their visits. What should you do?

A. Accept the gift so as not to offend anyone. However, report the gift to appropriate parties at your company so that you do not give the appearance of impropriety

B. Since the gift will not influence your future decisions, you can accept the gift as there is no conflict of interest

C. Since accepting the gift may give the appearance of impropriety you should decline the gift outright

D. Explain that the gift may be constructed as a conflict of interest and hence you cannot accept the gift

Answer: (SHOW ANSWER)

NEW QUESTION: 432

Which tool or technique of the Define Activities process allows for work to exist at various levels of detail depending on where it is in the project life cycle?

- A. Rolling wave planning
- B. Historical relationships
- C. Bottom-up estimating
- D. Dependency determination

Answer: ([SHOW ANSWER](#))

NEW QUESTION: 433

A project manager has just been informed that a key stakeholder communicated in writing to the vendor about an unauthorized acceptance of an intermediate project deliverable. This deliverable has not yet been fully tested and accepted.

What should the project manager do?

- A. Meet with the functional leader and confirm project acceptance
- B. Work with the team to expedite testing and acceptance of the deliverable
- C. Meet with the stakeholder to reinforce the agreed roles and responsibility matrix
- D. Facilitate a meeting between the sponsor and the functional leader to discuss

Answer: ([SHOW ANSWER](#))

Section: Executing

NEW QUESTION: 434

Ranking risks is performed in which of the following?

- A. Workarounds
- B. Risk triggers
- C. Qualitative Risk Analysis
- D. Expected monetary value (EMV).

Answer: C ([LEAVE A REPLY](#))

Section: Mix Questions

NEW QUESTION: 435

Which of the following is an input to the Qualitative Risk Analysis process?

- A. Risk register
- B. Risk data quality assessment
- C. Risk categorization
- D. Risk urgency

Answer: A ([LEAVE A REPLY](#))

Section: Initiation

NEW QUESTION: 436

A customer asks the project manager to estimate the time required to include a missing functionality. The customer thinks that three days will be sufficient to implement this change. However, the project management office (PMO) believes that seven days are required, while the technical lead feels that 10 days are needed.

What should the project manager use to estimate the time required for the change?

- A. Analogous estimating
- B. Parametric estimating
- C. Pareto diagram analysis
- D. Beta distribution

Answer: ([SHOW ANSWER](#))

Valid PMP Dumps shared by TrainingQuiz.com for Helping Passing PMP Exam!
TrainingQuiz.com now offer the **newest PMP exam dumps**, the TrainingQuiz.com PMP exam **questions have been updated** and **answers have been corrected** get the **newest** TrainingQuiz.com PMP dumps with Test Engine here: <https://www.trainingquiz.com/PMP-practice-quiz.html> (2045 Q&As Dumps, **40%OFF Special Discount: Exam-Tests**)

NEW QUESTION: 437

While reviewing prototypes, the quality team found some deviations that do not affect the main functionality but have the potential to be an issue in the future. To avoid major problems in the future, the team recommends corrective actions that will require additional funds. The project is already struggling to stay on budget and has even used some of the contingency reserves. What should the project manager do?

- A. Report to the project sponsor that the product is working and the project is struggling with the budget.
- B. Ask the quality team to discard the sample and test again with a new sample.
- C. Evaluate and initiate the change request process with the stakeholders.
- D. Ask the product designer why the deviation was not considered in the design phase.

Answer: C ([LEAVE A REPLY](#))

NEW QUESTION: 438

What is the tool and technique used to request seller responses?

- A. Contract types
- B. Bidder conferences
- C. Procurement documents
- D. Expert judgment

Answer: B ([LEAVE A REPLY](#))

NEW QUESTION: 439

The process of identifying and documenting the specific actions to be performed to produce the project deliverables is known as:

- A. Control Schedule.
- B. Define Activities.
- C. Sequence Activities.
- D. Define Scope.

Answer: B ([LEAVE A REPLY](#))

NEW QUESTION: 440

A Pareto chart is a specific type of:

- A. histogram
- B. cause-and-effect diagram
- C. scatter diagram
- D. control chart

Answer: A ([LEAVE A REPLY](#))

NEW QUESTION: 441

A project manager is new to an organization and is assigned to a project that is currently in the planning stage.

Everyone involved in the project is very interested in it and they are pushing the project manager to advance it to the next stage. While reviewing the project's various plans, the project manager found out there is no defined cost management plan.

What should the project manager do next?

- A. Start project execution and use the project management plan as input for missing information.
- B. Inform the sponsor and request more time to revise the cost management plan.
- C. Use the work breakdown structure (WBS) to estimate the cost of the activities based on previous experience.
- D. Review the project charter to develop the cost management plan.

Answer: B ([LEAVE A REPLY](#))

Section: Planning

NEW QUESTION: 442

What is true for a project when a Phase gate approach is being used?

- A. Phase gates are often used to verify entry criteria of a previous phase and exit criteria of the next one.
- B. Gates are often called kill points, when they are used to eliminate weak team members.
- C. Approaching phase gates early is a common signal that project planning has been poor.
- D. The order of phases must be strictly consecutive without overlapping in order to allow for gates.

Answer: D ([LEAVE A REPLY](#))

NEW QUESTION: 443

Which of the following statements best describes the influence of stakeholders and the cost of changes as project time advances?

- A. The influence of the stakeholders increases, the cost of changes decreases.
- B. The influence of the stakeholders decreases, the cost of changes decreases.
- C. The influence of the stakeholders decreases, the cost of changes increases.
- D. The influence of the stakeholders increases, the cost of changes increases.

Answer: C ([LEAVE A REPLY](#))

NEW QUESTION: 444

Due to a statewide emergency, a project team for a global insurance company is being forced to complete a project virtually. The project manager is tasked with conducting meetings where confidential patient information will be presented.

What tool should the project manager use to conduct meetings with the project team and clients?

- A. Use a popular social media platform.
- B. Use a password-enabled audio/video product.
- C. Use a collaborative electronic whiteboard.
- D. Use a third-party instant messaging tool.

Answer: B ([LEAVE A REPLY](#))

NEW QUESTION: 445

What type of reward can hurt team cohesiveness?

- A. Sole-sum
- B. Win-lose
- C. Lose-win
- D. Partial-sum

Answer: B ([LEAVE A REPLY](#))

Section: Closing

Explanation

NEW QUESTION: 446

A project manager is planning a project that has 40 stakeholders. The project manager decides that all stakeholders will receive the same type of communications in order to minimize work for the project team and reduce costs. When the project manager reviews the communications management plan with the project management team, an experienced team member voices concerns about the communications decision.

Why might using the same type of communication for all 40 stakeholders be a concern?

- A. Because different stakeholder needs are not being taken into consideration.
- B. Because the expected savings would be minimal
- C. Because some stakeholders might feel neglected.
- D. Because the team should be able to manage individual communications properly.

Answer: D ([LEAVE A REPLY](#))

NEW QUESTION: 447

Contract negotiations are NOT required when_____

- A. A company uses sealed bids
- B. There is a sole source procurement
- C. A competitive range is established
- D. A two-step process is used

Answer: ([SHOW ANSWER](#))

Section: Mix Questions

Explanation:

When using the sealed bid method, competitive market forces determine the price, and the award goes to the lowest bidder, provided all other terms and conditions of the contract are met.

NEW QUESTION: 448

Because your project is slated to last five years, you believe rolling wave planning is appropriate.

It provides information about the work to be done_____.

- A. Throughout all project phases
- B. For successful completion of the current project phase
- C. For successful completion of the current and subsequent project phases
- D. In the next project phase

Answer: C ([LEAVE A REPLY](#))

Section: Mix Questions

Explanation

Explanation:

Rolling wave planning provides progressive detailing of the work to be accomplished throughout the life of the project, indicating that planning and documentation are iterative and ongoing processes.

NEW QUESTION: 449

Which is NOT an input to the Create WBS process?

- A. Organizational Process Assets
- B. Scope Management Plan
- C. Project Scope Statement
- D. WBS Dictionary

Answer: D ([LEAVE A REPLY](#))

The WBS Dictionary is an output of the Create WBS process. It is created along with the WBS and gives all of the details about each work package in the WBS.

NEW QUESTION: 450

The information-gathering techniques used in the Risk Identification process include all of the following except _____.

- A. SWOT analysis
- B. root cause identification
- C. checklist analysis
- D. the Delphi technique

Answer: C (LEAVE A REPLY)

The information-gathering techniques in the Risk Identification process are brainstorming, the Delphi technique, interviewing, root cause identification, and SWOT analysis.

NEW QUESTION: 451

An element of the modern quality management approach used to achieve compatibility with the International Organization for Standardization (ISO) is known

as:

- A. Forecasting,
- B. Brainstorming.
- C. Cost of quality.
- D. Historical databases.

Answer: C (LEAVE A REPLY)

Valid PMP Dumps shared by TrainingQuiz.com for Helping Passing PMP Exam!

TrainingQuiz.com now offer the **newest PMP exam dumps**, the TrainingQuiz.com PMP exam **questions have been updated** and **answers have been corrected** get the **newest** TrainingQuiz.com PMP dumps with Test Engine here: <https://www.trainingquiz.com/PMP-practice-quiz.html> (2045 Q&As Dumps, **40%OFF Special Discount: Exam-Tests**)

NEW QUESTION: 452

You are the project manager for an information technology division of a large health care provider in the United States. Due to the new regulatory requirements enacted by HIPAA to ensure the privacy of confidential medical records, you have been assigned to audit all I.T systems to ensure compliance.

You need to ensure that all data stored in the data base is encrypted to ensure confidentiality.

You need to ensure that all users are properly authenticated. You also need to verify that authorization to confidential information follows the least privilege principle The deadline to ensure compliance with HIPAA regulations is within 120 days. Failing to complete the project within 120 days will result in significant fines to your organization. You have been given a budget is fixed and cannot be increased.

Which of the following statements are true?

- A. This project came about due to risk mitigation, and the primary constraint is budget

- B. This project came about due to legal requirements, and the primary constraint is schedule
- C. This project came about due to legal requirements, and the primary constraint is the budget
- D. This project came about due to risk mitigation, and the primary constraint is schedule

Answer: B ([LEAVE A REPLY](#))

NEW QUESTION: 453

During the setup of an agile project, the product owner expressed clear interest in having features released during product development over having the product completed in one year. What should the project manager do?

- A. Create a reward system recognizing group contributions to get people motivated and improve performance.
- B. Facilitate sprint planning sessions with a focus on defining the minimum viable product (MVP).
- C. Promote a productive environment where everybody can work without interruptions from the rest of the team members.
- D. Design a set of metrics including velocity, which is a good measure of value delivered.

Answer: B ([LEAVE A REPLY](#))

NEW QUESTION: 454

A project manager must obtain approval for a network cabling project. After preparation of detailed project information, some team members remain dissatisfied, as the selected equipment is new and insufficiently tested. The project manager determines that the equipment meets technology needs.

What skills should the project manager use to obtain team consensus and sponsor approval?

- A. Interpersonal
- B. Leadership
- C. Team-building
- D. Stakeholder engagement

Answer: A ([LEAVE A REPLY](#))

NEW QUESTION: 455

Your project has a budget of \$1.5 million for the first year, \$3 million for the second year, \$2.2 million for the third year, and \$800,000 for the fourth year. Most of the project budget will be spent during_____

- A. Starting the project
- B. Organizing and preparing
- C. Carrying out the work
- D. Closing the project

Answer: C ([LEAVE A REPLY](#))

Explanation/Reference:

Explanation:

The implementation phase (carrying out the work) is when all interfaces affecting the project must be coordinated and when the product or service of the project is created. In most projects, this phase is also where a large portion of the project budget is spent.

NEW QUESTION: 456

You are currently in the process of analyzing activity sequences, duration, resource requirements, and schedule to create the project schedule. Which of the following are not tools/ techniques you can use?

- A. Applying project calendars and resource calendars to identify periods when work and resource is available/allowed.
- B. Calculating theoretical early start/finish dates and late start/finish dates by performing a forward pass and backward pass analysis on project schedule network paths.
- C. Reallocating resources from non-critical to critical activities
- D. Crashing, fast-tracking
- E. Estimating the basis of activity duration by multiplying the quantity of work to be performed by the productivity rate.

Answer: E (LEAVE A REPLY)

NEW QUESTION: 457

Diagram:

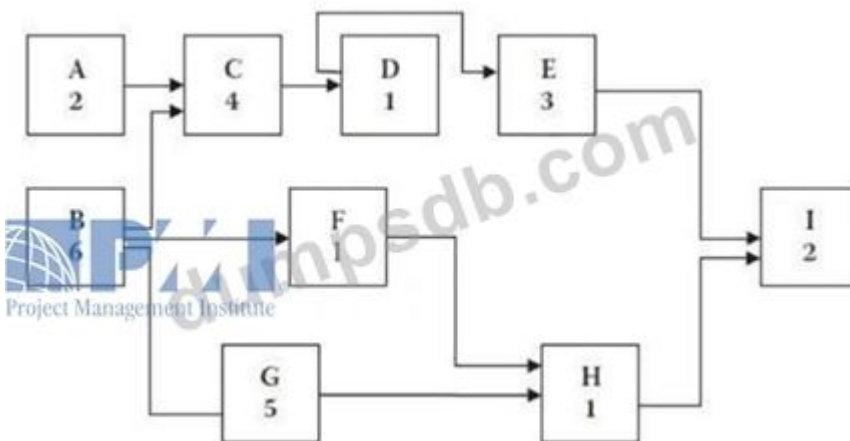

If a project planner imposes a finish time of 14 on the project with no change in the start date or activity durations, what is the total float of Activity E?

- A. -1
- B. 0
- C. 2
- D. Cannot be determined

Answer: A (LEAVE A REPLY)

Section: Mix Questions

Explanation:

The imposed finish date becomes the late finish for Activity I. The late dates for each activity need to be recalculated. The dates for Activity E become _____ ES = 10 EF = 13 LS = 9 LF = 12 Total float = LS - ES or 9 - 10 = (-1) or LS - EF or 12 - 13 = (-1)

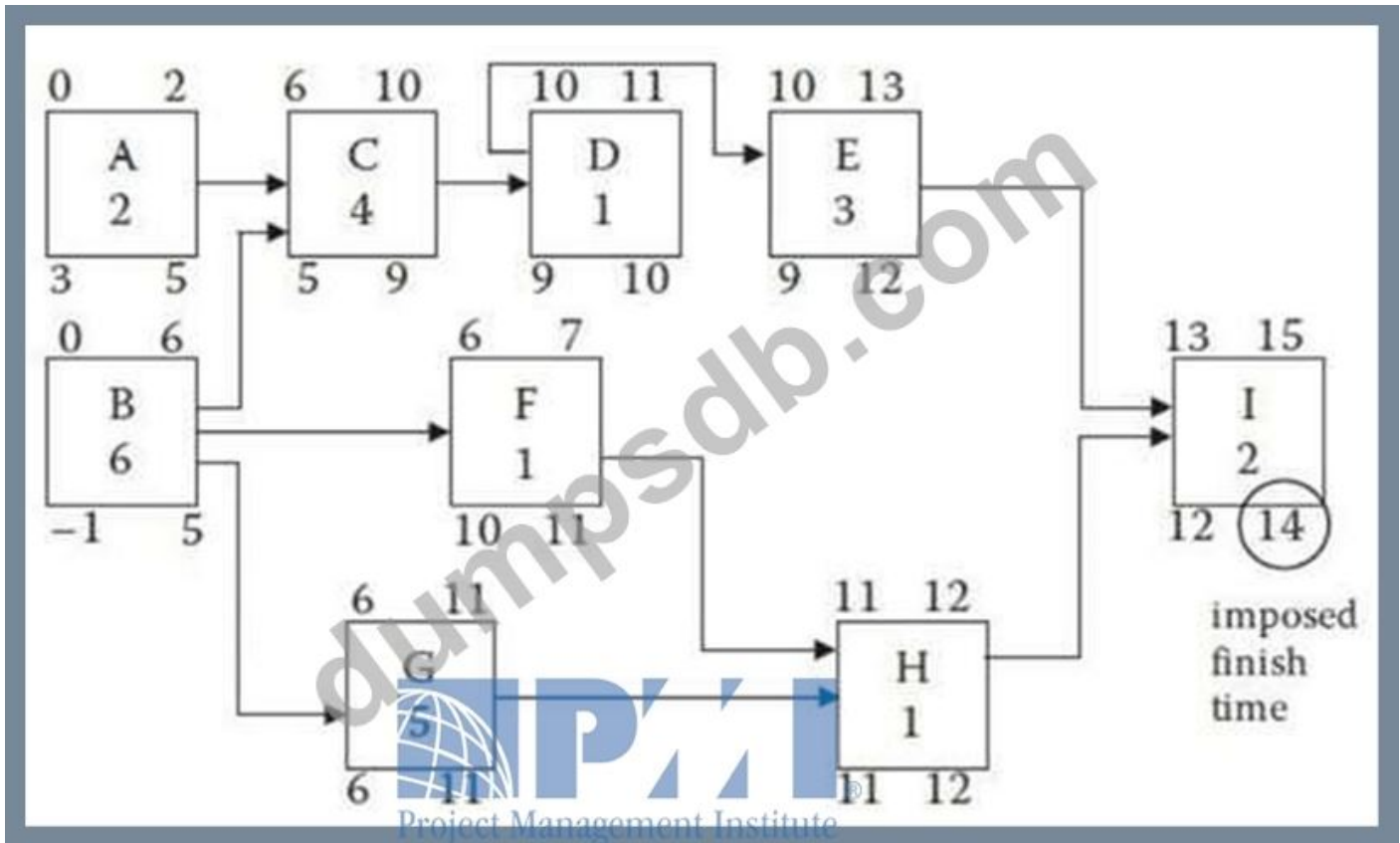

NEW QUESTION: 458

Work completed, key performance indicators, technical performance measures, start and finish dates of schedule activities, number of change requests, number of defects, actual costs, and actual decisions are examples of work performance data are an output of _____

- A. Project plan development
- B. Risk control
- C. Monitor and control project work
- D. Direct and manage project work

Answer: D (LEAVE A REPLY)

Explanation/Reference:

Explanation:

Work performance data containing these examples are an output of direct and manage project work. They are raw observations and measurements identified as activities are being performed to complete the work of the project. These data often are viewed at the lowest level of detail from which information is derived by other processes. The data then are gathered as the work is done and passed to the controlling processes of the various processes for further analyses.

NEW QUESTION: 459

Assigned risk ratings are based upon:

- A. Root cause analysis.
- B. Risk probability and impact assessment.
- C. Expert judgment.
- D. Revised stakeholders' tolerances.

Answer: B ([LEAVE A REPLY](#))

Section: Initiation

NEW QUESTION: 460

What is the estimate at completion (EAC) if the budget at completion (BAC) is \$100, the actual cost (AC) is

\$50, and the earned value (EV) is \$25?

- A. \$50
- B. \$100
- C. \$125
- D. \$200

Answer: (SHOW ANSWER)

Explanation/Reference:

Explanation:

$EAC = BAC / CPI$ and $CPI = EV / AC$

$CPI = EV / AC = 25 / 50 = 0.5$

$EAC = BAC / CPI = 100 / 0.5 = \200

NEW QUESTION: 461

Using the three-point estimating technique, if the most likely duration is four months, the optimistic duration is two months, and the pessimistic duration is one year, how many months is the expected activity duration?

- A. Two
- B. Five
- C. Four
- D. Twelve

Answer: (SHOW ANSWER)

NEW QUESTION: 462

Those areas that a project manager considers to be true, real or certain are called:

- A. Assumptions
- B. Risks
- C. Planning levers
- D. Constraints

Answer: (SHOW ANSWER)

NEW QUESTION: 463

Specification of both the deliverables and the processes is the focus of:

- A. Change control
- B. Project monitoring and control
- C. Issue control
- D. Configuration control

Answer: A ([LEAVE A REPLY](#))

NEW QUESTION: 464

You are managing a project and the sponsor has removed the previous Project Manager on the project because they could not keep the project on budget. According to your current project budget, this project is over budget by \$245,000. As the current Project Manager, you are afraid you will also be removed if you report this status. What is the best response you can tell senior management?

- A. Don't report the delay and begin looking for a new job
- B. Tell senior management the project is over budget by \$245,000 with a plan to recover
- C. Report the delay to senior management and the reasons
- D. The schedule is only two weeks behind so you don't report the delay

Answer: B ([LEAVE A REPLY](#))

NEW QUESTION: 465

During a documentation audit of an international company it was identified that the last version of the project schedule was from one month ago even though the project manager knew it was recently updated How should the project manager have handled documentation for the project?

- A. Updated the project management plan regularly and had it securely shared with all stakeholders
- B. Assigned a project team member to ensure all project documentation was updated
- C. Kept documentation in the project management information system (PMIS), and shared it with appropriate stakeholders
- D. Reviewed the risk register to identify a response plan for the audit

Answer: ([SHOW ANSWER](#))

NEW QUESTION: 466

An experienced project manager joins a project that has been ongoing for six months During their first meeting with stakeholders, the project manager learns of a customer concern that their expectations are not being met.

What should the project manager reference to address this concern?

- A. Assumption log
- B. Project charter
- C. Stakeholder engagement plan
- D. Scope management plan

Answer: D ([LEAVE A REPLY](#))

Valid PMP Dumps shared by TrainingQuiz.com for Helping Passing PMP Exam!
TrainingQuiz.com now offer the **newest PMP exam dumps**, the TrainingQuiz.com PMP exam **questions have been updated** and **answers have been corrected** get the **newest** TrainingQuiz.com PMP dumps with Test Engine here: <https://www.trainingquiz.com/PMP-practice-quiz.html> (2045 Q&As Dumps, **40%OFF** Special Discount: **Exam-Tests**)

NEW QUESTION: 467

The lessons learned documentation is an output from the _____

- A. Identify stakeholders process
- B. Develop project management plan process
- C. Manage communications process
- D. Plan communications management process

Answer: C (LEAVE A REPLY)

Explanation/Reference:

Explanation:

Lessons learned documentation is an output of the manage communications process. It is an element of the organizational process assets updates. It includes the causes of issues, reasons for corrective actions selected, and other types of lessons learned about communications management.

NEW QUESTION: 468

When is a project finished?

- A. After verbal acceptance of the customer or sponsor
- B. After lessons learned have been documented in contract closure
- C. When the project objectives have been met
- D. After resources have been released

Answer: C (LEAVE A REPLY)

Section: Closing

NEW QUESTION: 469

You are managing a construction project. You have included the measurable project objectives and related success criteria in the Quality Management Plan. While reviewing your plan, the project sponsor asks you to reconsider this. You then realize that what you did is incorrect. Where should you place the measurable project objectives and related success criteria?

- A. Change Management plan
- B. Project Scope Statement
- C. Project Charter
- D. Quality Management Plan

Answer: C ([LEAVE A REPLY](#))

NEW QUESTION: 470

An agile project team is building a new product. The stakeholders require ongoing illustration of project business value.

How should the project manager proceed?

- A. Prepare performance value reports for the business on an ongoing basis.
- B. Include demonstrations of the built portion of the product at the end of every sprint.
- C. Confirm the minimum viable product (MVP) and demonstrate it to the business when it is ready.
- D. Prepare a project report for the stakeholders and distribute it weekly.

Answer: ([SHOW ANSWER](#))

NEW QUESTION: 471

Which of the following are not the direct result of managing the team?

- A. Submitting change request and resolving issues
- B. Updating and staffing the management plan
- C. Developing input to performance appraisals
- D. Recording the lessons learned
- E. Identifying the recourse requirements

Answer: ([SHOW ANSWER](#))

NEW QUESTION: 472

An input to the Manage Project Team process is:

- A. Change requests.
- B. Work performance reports.
- C. Activity resource requirements.
- D. Enterprise environmental factors.

Answer: B ([LEAVE A REPLY](#))

NEW QUESTION: 473

During which of the following phases is a project's scope statements developed?

- A. The initiation phase.
- B. The implementation phase.
- C. The planning phase.
- D. The definition phase.
- E. The verification phase.

Answer: C ([LEAVE A REPLY](#))

NEW QUESTION: 474

Which of the following lists contain processes that are included within Project Procurement Management?

- A. Plan purchases and acquisitions, acquire project team, request seller responses, select sellers
- B. Plan purchases and acquisitions, acquire project team, contract approval, select sellers
- C. Plan purchases and acquisitions, request seller responses, select sellers, schedule control
- D. Plan purchases and acquisitions, plan contracting, request seller responses, select sellers

Answer: ([SHOW ANSWER](#))

NEW QUESTION: 475

The process of monitoring the status of the project to update project progress and manage changes to the schedule baseline is:

- A. Control Schedule.
- B. Quality Control.
- C. Perform Integrated Change Control.
- D. Develop Schedule.

Answer: A ([LEAVE A REPLY](#))

Section: Executing

Explanation/Reference:

NEW QUESTION: 476

A contract has just been awarded for an automation project that was supported by the local community. The project manager was warned by the elected officials that the project cannot proceed.

Why did this action occur?

- A. Lack of a proper legal framework in place
- B. Inadequate engagement of the political stakeholders
- C. Lack of competence to manage the automation project
- D. Inadequate funds for the automation project

Answer: ([SHOW ANSWER](#))

NEW QUESTION: 477

A project manager is developing a schedule for a communications project. The available project information is vague. What should the project manager do to address this?

- A. Assign a contingency reserve for uncertain activities.
- B. Meet with the project team to estimate activity durations.
- C. Determine activity durations using three-point estimating.
- D. Increase the total float of all activities.

Answer: C ([LEAVE A REPLY](#))

NEW QUESTION: 478

Which illustrates the connection between work that needs to be done and its project team members?

- A. Staffing management plan
- B. Network diagrams
- C. Work breakdown structure
- D. Responsibility matrix

Answer: ([SHOW ANSWER](#))

NEW QUESTION: 479

A company's CEO complains about the frequency of project communications. The CEO receives five project reports each week by email but does not have enough time to review them. In addition, the information that the CEO receives is not relevant in that it does not explain the project status, What should the project manager do first?

- A. Send the CEO one executive summary per week instead of five reports per week.
- B. Review the stakeholder engagement plan.
- C. Review the communications management plan.
- D. Meet with the team and decide the type and frequency of the reports to send to the CEO.

Answer: D ([LEAVE A REPLY](#))

NEW QUESTION: 480

You are implementing a project management methodology for your company that requires you to establish a change control board. Which one of the following statements best describes a change control board?

- A. Recommended for use on all (large and small) projects
- B. Used to review, evaluate, approve, delay, or reject changes to the project
- C. Managed by the project manager, who also serves as its secretary
- D. Composed of key project team members

Answer: B ([LEAVE A REPLY](#))

Section: Mix Questions

Explanation:

Used to review, evaluate, approve, delay, or reject changes to the project The change control board's powers and responsibilities should be well defined and agreed upon by key stakeholders. On some projects, multiple change control boards may exist with different areas of responsibility.

NEW QUESTION: 481

You are the project manager for a construction project. The project is currently in the implementation phase.

You would like to know more about the project key deliverables, constraints, and assumptions. Which of the following documents would be most useful for this purpose?

- A. Scope Management Plan
- B. Project scope statement

- C. Requirements documentation
- D. Project Management Plan

Answer: ([SHOW ANSWER](#))

Valid PMP Dumps shared by TrainingQuiz.com for Helping Passing PMP Exam!
TrainingQuiz.com now offer the **newest PMP exam dumps**, the TrainingQuiz.com PMP exam **questions have been updated** and **answers have been corrected** get the **newest** TrainingQuiz.com PMP dumps with Test Engine here: <https://www.trainingquiz.com/PMP-practice-quiz.html> (2045 Q&As Dumps, **40%OFF** Special Discount: **Exam-Tests**)

NEW QUESTION: 482

Create Procurement document is done in _____.

- A. Conduct Procurements
- B. Administer Procurements
- C. Plan Procurements
- D. Close Procurements

Answer: ([SHOW ANSWER](#))

Create Procurement document is done in Plan Procurements process.

NEW QUESTION: 483

A project manager for a large project's agile team is developing new workflows to meet changing business needs. As the second sprint is running, the product owner and agile team begin to receive more details that impact the scope change of running items. The agile team requests a change in the sprint goals and sprint backlog items.

What should the project manager do?

- A. Moderate the expectations for sprint quality.
- B. Guide the agile team to add the new scope to the product backlog.
- C. Pause the sprint to allow time to include the new items.
- D. Create a parallel sprint to deliver the additional items.

Answer: ([SHOW ANSWER](#))

NEW QUESTION: 484

Work performance information in control risks means that _____

- A. Recommended preventive or corrective action is considered through change requests
- B. Outcomes of risk reassessments and risk audits are documented
- C. Templates to the risk management plan and the risk register are recommended
- D. A mechanism to communicate and support project decision making is provided

Answer: D ([LEAVE A REPLY](#))

Explanation/Reference:

Explanation:

All of the answers are outputs in the control risks process, however, work performance information specifically provides a mechanism to communicate and support project decision making.

NEW QUESTION: 485

In Project Cost Management, which input is exclusive to the Determine Budget process?

- A. Scope baseline
- B. Organizational process assets
- C. Project schedule
- D. Resource calendars

Answer: D (LEAVE A REPLY)

Section: Monitoring and Controlling

NEW QUESTION: 486

A sponsor proposes a project scope change that is popular with the project team and Key stakeholders. what should the project manager do?

- A. Update the project requirements.
- B. Follow the scope change request process.
- C. Modify the work breakdown structure (WBS).
- D. Notify stakeholders of the change.

Answer: B (LEAVE A REPLY)

NEW QUESTION: 487

Collecting requirements is critical in project scope management as it becomes the foundation for the project's _____

- A. Scope management plan
- B. WBS
- C. Schedule
- D. Scope change control system

Answer: B (LEAVE A REPLY)

Section: Mix Questions

Explanation:

Collecting requirements provides the basis for defining project scope and product scope. It also involves determining, documenting, and managing stakeholder needs to meet project objectives. The requirements become the foundation for the WBS; moreover, cost, schedule, and quality planning are built upon the requirements.

Valid PMP Dumps shared by TrainingQuiz.com for Helping Passing PMP Exam!
TrainingQuiz.com now offer the **newest PMP exam dumps**, the TrainingQuiz.com PMP exam **questions have been updated** and **answers have been corrected** get the **newest** TrainingQuiz.com PMP dumps with Test Engine here: <https://www.trainingquiz.com/PMP-practice-quiz.html> (**2045** Q&As Dumps, **40%OFF** Special Discount: **Exam-Tests**)